

- (四) 提議召開臨時股東大會，在董事會不履行《公司法》規定的召集和主持股東大會職責時召集和主持股東大會；
- (五) 向股東大會提出提案；
- (六) 提議召開董事會臨時會議；
- (七) 依照《公司法》第一百五十二條的規定，對董事、高級管理人員提起訴訟；
- (八) 法律、行政法規及公司章程規定的其他職權。

監事列席董事會會議。

第一百二十二條 監事會每六個月至少召開一次會議，由監事會主席負責召集。監事會主席不能履行職務或者不履行職務的，由半數以上監事共同推舉一名監事召集和主持監事會會議。

監事可以提議召開臨時監事會會議。

召開定期監事會會議和臨時監事會會議，監事會工作人員應當分別提前10日和5日將蓋有監事會印章的書面會議通知，通過直接送達、傳真、電子郵件或者其他方式，提交全體監事。非直接送達的，還應當通過電話進行確認並做相應記錄。

情況緊急，需要盡快召開監事會臨時會議的，可以隨時通過電話或者其他口頭方式發出會議通知，但召集人應當在會議上作出說明。

第一百二十三條 監事會的議事方式為：監事會會議的表決實行一人一票，以記名和書面等方式進行。



《公司法》
主持股

表決程序為：監事的表決意向分為同意、反對和棄權。與會監事應當從上述意向中選擇其一，未做選擇或者同時選擇兩個以上意向的，會議主席應當要求該監事重新選擇，拒不選擇的，視為棄權；中途離開會場不回而未做選擇的，視為棄權。

監事會的決議，應當由2/3以上監事會成員表決通過。

董事、高

監事會應當將所議事項的決定做成會議記錄，出席會議的監事應當在會議記錄上簽名。監事有權要求在記錄上對其在會議上的發言作出某種說明性記載。監事會會議記錄應當在公司住所保存。

負責召
由半數

第一百二十四條 監事會發現公司經營情況異常，可以進行調查；必要時，可以聘請律師和會計師事務所等專業人士協助其工作，為此而支出的合理費用由公司承擔。

第一百二十五條 監事應當依照法律、行政法規及公司章程的規定，忠實履行監督職責。

第十四章 公司董事、監事、總經理和其他高級管理人員的資格和義務

作人員
會議通
，提交
認並做

第一百二十六條 有下列情況之一的，不得擔任公司的董事、監事、總經理或者其他高級管理人員：

隨時通
應當在

- (一) 無民事行為能力或者限制民事行為能力；
- (二) 因貪污、賄賂、侵佔財產、挪用財產或者破壞社會主義市場經濟秩序，被判處刑罰，執行期滿未逾5年，或者因犯罪被剝奪政治權利，執行期滿未逾5年；
- (三) 擔任破產清算的公司、企業的董事或者廠長、經理，對該公司、企業的破產負有個人責任的，自該公司、企業破產清算完結之日起未逾3年；

一票，

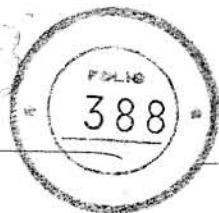

- (四) 擔任因違法被吊銷營業執照、責令關閉的公司、企業的法定代表人，並負有個人責任的，自該公司、企業被吊銷營業執照之日起未逾3年；
- (五) 個人所負數額較大的債務到期未清償；
- (六) 因觸犯刑法被司法機關立案調查，尚未結案；
- (七) 法律、行政法規規定不能擔任企業領導；
- (八) 非自然人；
- (九) 被有關主管機構裁定違反有關證券法規的規定，且涉及有欺詐或者不誠實的行為，自該裁定之日起未逾5年；
- (十) 公司股票上市地的有關法律法規所指定的情況。

第一

第一百二十七條 公司董事、總經理和其他高級管理人員代表公司的行為對善意第三人的有效性，不因其任職、選舉或者資格上有任何不合規行為而受影響。

第一百二十八條 除法律、行政法規或者公司股票上市的證券交易所的上市規則要求的義務外，公司董事、監事、總經理和其他高級管理人員在行使公司賦予他們的職權時，還應當對每個股東負有下列義務：

- (一) 不得使公司超越其營業執照規定的營業範圍；
- (二) 應當真誠地以公司最大利益為出發點行事；
- (三) 不得以任何形式剝奪公司財產，包括（但不限於）對公司有利的機會；

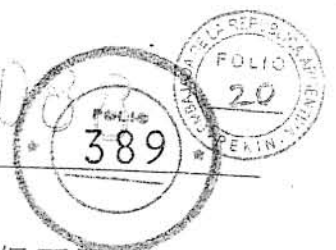

公司、
該公司、

(四) 不得剝奪股東的個人權益，包括(但不限於)分配權、表決權，但不包括根據本章程提交股東大會通過的公司改組。

公司董事、監事、總經理和其他高級管理人員都有責任在行使其權利或者履行其義務時，以一個合理的謹慎的人在相似情形下所應表現的謹慎、勤勉和技能為其所應為的行為。

公司可以建立必要的董事、監事和高級管理人員責任保險制度，以降低該等人員正常履行職責可能引致的風險。

第一百二十九條

公司董事、監事、總經理和其他高級管理人員在履行職責時，必須遵守誠信原則，不應當置自己於自身的利益與承擔的義務可能發生衝突的處境。此原則包括(但不限於)履行下列義務：

- (一) 真誠地以公司最大利益為出發點行事；
- (二) 在其職權範圍內行使權力，不得越權；
- (三) 親自行使所賦予他的酌量處理權，不得受他人操縱；非經法律、行政法規允許或者得到股東大會在知情的情況下的同意，不得將其酌量處理權轉給他人行使；
- (四) 對同類別的股東應當平等，對不同類別的股東應當公平；
- (五) 除本章程另有規定或者由股東大會在知情的情況下另有批准外，不得與公司訂立合同、交易或者安排；
- (六) 未經股東大會在知情的情況下同意，不得以任何形式利用公司財產為自己謀取利益；
- (七) 不得利用職權收受賄賂或者其他非法收入，不得以任何形式侵佔公司的財產，包括(但不限於)對公司有利的機會；

規定，且
：日起未

兄。

行為對
格上有

的上市
他高級
每個股

於)對

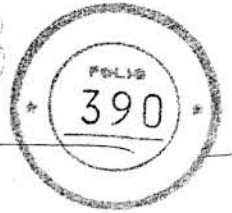

- (八) 未經股東大會在知情的情況下同意，不得接受與公司交易有關的佣金；
- (九) 遵守本章程，忠實履行職責，維護公司利益，不得利用其在公司的地位和職權為自己謀取私利；
- (十) 未經股東大會在知情的情況下同意，不得以任何形式與公司競爭；
- (十一) 不得挪用公司資金，不得將公司資產或者資金以其個人名義或者以其他名義開立賬戶存儲；不得違反本章程的規定，未經股東大會或董事會同意，將公司資金借貸給他人或者以公司財產為公司的股東或者其他個人提供擔保；
- (十二) 未經股東大會在知情的情況下同意，不得洩露其在任職期間所獲得的涉及本公司的機密信息；除非以公司利益為目的，亦不得利用該信息；但是，在下列情況下，可以向法院或者其他政府主管機構披露該信息：
- 1、 法律有規定；
 - 2、 公眾利益有要求；
 - 3、 該董事、監事、總經理和其他高級管理人員本身的利益有要求。

本條所述人員違反本條規定所得的收入，應當歸公司所有；給公司造成損失的，應當承擔賠償責任。

第一百三十條

公司董事、監事、總經理和其他高級管理人員，不得指使下列人員或者機構（「相關人」）作出董事、監事、總經理和其他高級管理人員不能做的事：

- (一) 公司董事、監事、總經理和其他高級管理人員的配偶或者未成年子女；

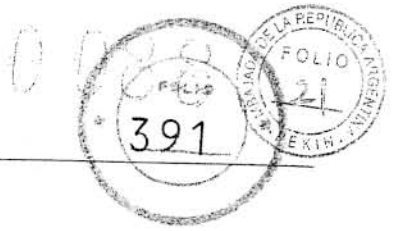

接受與公
益，不得
以任何形
式以其
不得違反
法，將公
司股東或
者其在
除非以
下，在下
後構披露
人員本
公司所
得指使
經理和
員的配

- (二) 公司董事、監事、總經理和其他高級管理人員或者本條(一)項所述人員的信託人；
- (三) 公司董事、監事、總經理和其他高級管理人員或者本條(一)、(二)項所述人員的合夥人；
- (四) 由公司董事、監事、總經理和其他高級管理人員在事實上單獨控制的公司，或者與本條(一)、(二)、(三)項所提及的人員或者公司其他董事、監事、總經理和其他高級管理人員在事實上共同控制的公司；及
- (五) 本條(四)項所指被控制的公司的董事、監事、總經理和其他高級管理人員。

第一百三十一條 公司董事、監事、總經理和其他高級管理人員所負的誠信義務不一定因其任期結束而終止，其對公司商業秘密保密的義務在其任期結束後仍有效。其他義務的持續期應當根據公平的原則決定，取決於事件發生時與離任之間時間的長短，以及與公司的關係在何種情形和條件下結束。

第一百三十二條 公司董事、監事、總經理和其他高級管理人員因違反某項具體義務所負的責任，可以由股東大會在知情的情況下解除，但是本章程第五十一條所規定的情形除外。

第一百三十三條 公司董事、監事、總經理和其他高級管理人員，直接或者間接與公司已訂立的或者計劃中的合同、交易、安排有重要利害關係時，(公司與董事、監事、總經理和其他高級管理人員的聘任合同除外)，不論有關事項在正常情況下是否需要董事會批准同意，均應當盡快向董事會披露其利害關係的性質和程度。

董事不得就其擁有重大權益的合同、交易或安排進行投票，亦不得列入會議的法定人數。

除非有利害關係的公司董事、監事、總經理和其他高級管理人員按照本條第一款的要求向董事會做了披露，並且董事會在不將其計入法定人數，亦未參加表決的會議上批准了該事項，公司有權撤銷該合同、交易或者安排，但在對方是對有關董事、監事、總經理和其他高級管理人員違反其義務的行為不知情的善意當事人的情形下除外。

公司董事、監事、總經理和其他高級管理人員的相關人與某合同、交易、安排有利害關係的，有關董事、監事、總經理和其他高級管理人員也應被視為有利害關係。

第一百三十四條 如果公司董事、監事、總經理和其他高級管理人員在公司首次考慮訂立有關合同、交易、安排前以書面形式通知董事會，聲明由於通知所列的內容，公司日後達成的合同、交易、安排與其有利害關係，則在通知闡明的範圍內，有關董事、監事、總經理和其他高級管理人員視為做了本章前條所規定的披露。

第一百三十五條 公司不得以任何方式為其董事、監事、總經理和其他高級管理人員繳納稅款。

第一百三十六條 公司不得直接或者間接向本公司和其母公司的董事、監事、總經理和其他高級管理人員提供貸款、貸款擔保；亦不得向前述人員的相關人提供貸款、貸款擔保。

前款規定不適用於下列情形：

- (一) 公司向其子公司提供貸款或者為子公司提供貸款擔保；
- (二) 公司根據經股東大會批准的聘任合同，向公司的董事、監事、總經理和其他高級管理人員提供貸款、貸款擔保或者其他款項，使之支付為了公司目的或者為了履行其公司職責所發生的費用；及

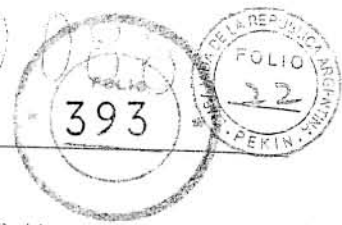

也高級管
並且董
事上批准
但在對
員違反

(三) 如公司的正常業務範圍包括提供貸款、貸款擔保，公司可以向有關董事、監事、總經理和其他高級管理人員及其相關人提供貸款、貸款擔保，但提供貸款、貸款擔保的條件應當是正常商務條件。

第一百三十七條 公司違反前條規定提供貸款的，不論其貸款條件如何，收到款項的人應當立即償還。

關人與
事、總

第一百三十八條 公司違反第一百三十六條第一款的規定所提供的貸款擔保，不得強制公司執行；但下列情況除外：

在公司
通知董
合同、
內，有
了本章

- (一) 向公司或者其母公司的董事、監事、總經理和其他高級管理人員的相關人提供貸款時，提供貸款人不知情的；
- (二) 公司提供的擔保物已由提供貸款人合法地售予善意購買者的。

第一百三十九條 本章前述條款中所稱擔保，包括由保證人承擔責任或者提供財產以保證義務人履行義務的行為。

他高級

第一百四十條 公司董事、監事、總經理和其他高級管理人員違反對公司所負的義務時，除法律、行政法規規定的各種權利、補救措施外，公司有權採取以下措施：

事、監
保；亦

- (一) 要求有關董事、監事、總經理和其他高級管理人員賠償由於其失職給公司造成的損失；
- (二) 撤銷任何由公司與有關董事、監事、總經理和其他高級管理人員訂立的合同或者交易，以及由公司與第三人（當第三人明知或者理應知道代表公司的董事、監事、總經理和其他高級管理人員違反了對公司應負的義務）訂立的合同或者交易；
- (三) 要求有關董事、監事、總經理和其他高級管理人員交出因違反義務而獲得的收益；
- (四) 追回有有關董事、監事、總經理和其他高級管理人員收受的本應為公司所收取的款項，包括（但不限於）佣金；

貸款擔

司的董
貸款、
目的或



(五) 要求有關董事、監事、總經理和其他高級管理人員退還因本應交予公司的款項所賺取的、或者可能賺取的利息；及

(六) 通過法律程序裁定讓董事、監事、總經理和其他高級管理人員因違反義務所獲得的財物歸公司所有。

第一百四十一條 公司應當就報酬事項與公司董事、監事訂立書面合同，並經股東大會事先批准。前述報酬事項包括：

第一百

(一) 作為公司的董事、監事或者高級管理人員的報酬；

第一百

(二) 作為公司的子公司的董事、監事或者高級管理人員的報酬；

(三) 為公司及其子公司的管理提供其他服務的報酬；及

(四) 該董事或者監事因失去職位或者退休所獲補償的款項。

除按前述合同外，董事、監事不得因前述事項為其應獲取的利益向公司提出訴訟。

公司應當定期向股東披露董事、監事、高級管理人員從公司獲得報酬的情況。

第一百

第一百四十二條 公司在與公司董事、監事訂立的有關報酬事項的合同中應當規定，當公司將被收購時，公司董事、監事在股東大會事先批准的條件下，有權取得因失去職位或者退休而獲得的補償或者其他款項。

第一百

前款所稱公司被收購是指下列情況之一：

第一百

(一) 任何人向全體股東提出收購要約；

(二) 任何人提出收購要約，旨在使要約人成為控股股東。控股股東的定義與本章程的定義相同。

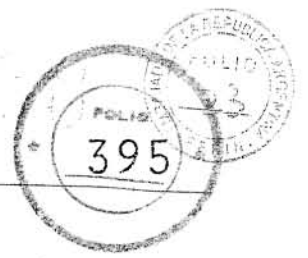

如果有關董事、監事不遵守本條規定，其收到的任何款項，應當歸那些由於接受前述要約而將其股份出售的人所有，該董事、監事應當承擔因按比例分發該等款項所產生的費用，該費用不得從該等款項中扣除。

第十五章 財務和會計制度

第一百四十三條 公司依照法律、行政法規和國家有關部門制定的規定，制定公司的財務會計制度。

第一百四十四條 公司會計年度採用公曆日曆年制，即每年公曆1月1日起至12月31日止為一會計年度。

公司應當在每一會計年度終了時製作財務報告，並依法經審查驗證。

公司的財務報表除應當按中國會計準則及法規編製外，還應當按國際或者境外上市地會計準則編製。如按兩種會計準則編製的財務報表有重要出入，應當在財務報表附註中加以註明。

公司在分配有關會計年度的稅後利潤時，以前述兩種財務報表中稅後利潤數較少者為準。

第一百四十五條 公司董事會應當在每次年度股東大會上，向股東呈交有關法律、行政法規、地方政府及主管部門頒佈的規範性文件所規定由公司準備的財務報告。

第一百四十六條 公司除法定的會計賬簿外，將不另立會計賬簿。公司的資產，不以任何個人名義開立賬戶存儲。

第一百四十七條 公司的財務報告應當在召開年度股東大會的20日以前置備於公司，供股東查閱。公司的每個股東都有權得到本章中所提及的財務報告。

公司至少應當在股東大會年會召開前21日將前述報告以郵資已付的郵件寄給每個境外上市外資股股東，收件人地址以股東的名冊登記的地址為準。

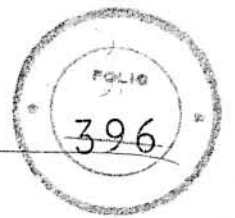

第一百四十八條 公司每一會計年度公佈兩次財務報告，即在一會計年度前6個月結束後的60天內公佈中期財務報告，會計年度結束後的120天內公佈年度財務報告。

公司公佈或者披露的中期業績或者財務資料應當按中國會計準則及法規編製，同時按國際或者境外上市地會計準則編製。

第十六章 利潤分配

第一百四十九條 利潤分配方案

公司分配當年稅後利潤時，應當提取利潤的10%列入公司法定公積金。公司法定公積金累計額為公司註冊資本的50%以上的，可以不再提取。

公司的法定公積金不足以彌補以前年度虧損的，在依照前款規定提取法定公積金之前，應當先用當年利潤彌補虧損。

公司從稅後利潤中提取法定公積金後，經股東大會決議，還可以從稅後利潤中提取任意公積金。

公司彌補虧損和提取公積金後所餘稅後利潤，為可供股東分配的利潤，由公司根據公司股東大會決議按股東持有的股份比例分配。

股東大會違反前款規定，在公司彌補虧損和提取法定公積金之前向股東分配利潤的，股東必須將違反規定分配的利潤退還公司。

公司持有的本公司股份不參與分配利潤。

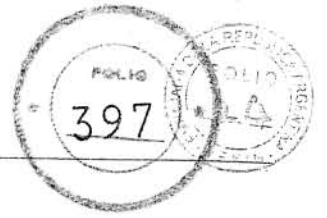

計年度
年度結

按中國
會計準

列入公司
母資本的

在依照前
補虧損。

會決議，

可供股東
持有的

去定公積
分配的利

第一百五十條 資本公積金包括下列款項：

- (一) 超過股票面額發行所得的溢價款；
- (二) 國務院財政主管部門規定列入資本公積金的其他收入。

第一百五十一條 公司的公積金用於彌補公司的虧損、擴大公司生產經營或者轉為增加公司資本。但是，資本公積金將不用於彌補公司的虧損。

法定公積金轉為資本時，所留存的該項公積金將不少於轉增前公司註冊資本的25%。

第一百五十二條 公司可以下列形式（或同時採取兩種形式）分配股利：

- (一) 現金；
- (二) 股票。

第一百五十三條 股東在催繳股款前已繳付的任何股份的股款，均可享有利息，但無權就預繳股款參與其後宣佈的股息。

第一百五十四條 公司應當為持有境外上市外資股股份的股東委任收款代理人。收款代理人應當代有關股東收取公司就境外上市外資股股份分配的股利及其他應付的款項，並由其代為保管該等款項，以待支付有關股東。

公司委任的收款代理人應當符合上市地法律或者證券交易所所有關規定的要求。

公司委任的香港聯交所上市的境外上市外資股股東的收款代理人，應當為依照香港《受託人條例》註冊的信託公司。

在遵守中國有關法律、法規的前提下，對於無人認領的股利，公司可行使沒收權力，但該權力僅可在宣佈有關股利日期後六年或六年以後才能行使。

公司有權終止以郵遞方式向某境外上市外資股持有人發送股息券，但公司應在股息券連續兩次未予提現後方可行使此項權力。然而，如股息券在初次未能送達收件人而遭退回後，公司亦可行使此項權力。

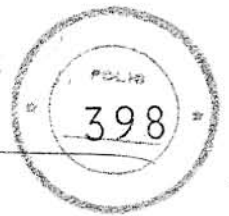

公司有權按董事會認為適當的方式出售未能聯絡的境外上市外資股股東的股票，但必須遵守以下的條件：

- (一) 有關股份於12年內最少應已派發3次股利，而於該段期間無人認領股利；
- (二) 公司於12年的期間屆滿後，於公司上市地的一份或以上的報章刊登公告，說明其擬將股份出售的意向，並知會該等股份上市的證券交易所。

第一百五十五條 公司向內資股股東支付現金股利和其他款項，以人民幣派付。公司向境外上市外資股股東支付現金股利和其他款項，以人民幣計價和宣佈，以港幣支付。公司向境外上市外資股股東支付現金股利和其他款項所需的外幣，按國家有關外匯管理的規定辦理。

第一百五十六條 除非有關法律、行政法規另有規定，用港幣支付現金股利和其他款項的，匯率應採用股利和其他款項宣佈當日之前一個公曆星期中國人民銀行公佈的有關外匯的平均賣出價。

第十七章 會計師事務所的聘任

第一百五十七條 公司應當聘用符合國家有關規定的、獨立的會計師事務所，審計公司的年度財務報告，並審核公司的其他財務報告。

公司的首任會計師事務所可以由創立大會在首次股東年會前聘任，該會計師事務所的任期在首次股東年會結束時終止。

第一百五十八條 公司聘用會計師事務所的聘期，自公司本次股東年會結束時起至下次股東年會結束時止。

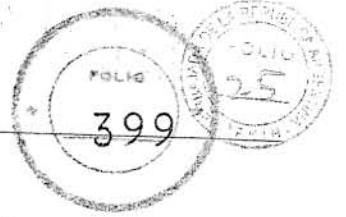

境外上

第一百五十九條 經公司聘用的會計師事務所享有下列權利：

於該段

(一) 隨時查閱公司的賬簿、記錄或者憑證，並有權要求公司的董事、總經理或者其他高級管理人員提供有關資料和說明；

的一份
售的意

(二) 要求公司採取一切合理措施，從其子公司取得該會計師事務所為履行職務而必需的資料和說明；

民幣派
其他款
外上市
按國家

(三) 出席股東會議，得到任何股東有權收到的會議通知或者與會議有關的其他信息，在任何股東會議上就涉及其作為公司的會計師事務所的事宜發言。

金股利
日之前
出價。

公司應向聘用的會計師事務所提供真實、完整的會計憑證、會計賬簿、財務會計報告及其他會計資料，不得拒絕、隱匿、謊報。

第一百六十條

如果會計師事務所職位出現空缺，董事會在股東大會召開前，可以委任會計師事務所填補該空缺。但在空缺持續期間，公司如有其他在任的會計師事務所，該等會計師事務所仍可行事。

師事務
財務報

第一百六十一條

不論會計師事務所與公司訂立的合同條款如何規定，股東大會可以在任何會計師事務所任期屆滿前，通過普通決議決定將該會計師事務所解聘。有關會計師事務所如有因被解聘而向公司索償的權利，有關權利不因此而受影響。

東年會
東時終

第一百六十二條

會計師事務所的報酬或者確定報酬的方式由股東大會決定。

會結束

第一百六十三條

公司聘用、解聘或者不再續聘會計師事務所由股東大會作出決定，並報國務院證券主管機構備案。

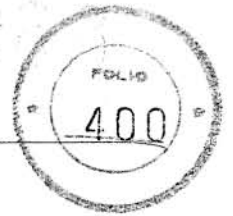

股東大會在擬通過決議，聘任一家非現任的會計師事務所，以填補會計師事務所職位的任何空缺，或續聘一家由董事聘任填補空缺的會計師事務所，或解聘一家任期未屆滿的會計師事務所時，應當按以下規定辦理：

- (一) 有關聘任或續聘或解聘的提案在股東大會會議通知發出之前，應當送給擬聘任的或擬離任的或在有關會計年度已離任的會計師事務所。

離任包括被解聘、辭聘和退任。

- (二) 如果即將離任的會計師事務所作出書面陳述，並要求公司將該陳述告知股東，公司除非收到書面陳述過遲，否則應當採取以下措施：

- 1、 在為作出決議而發出的通知上說明將離任的會計事務所作出了陳述；及
- 2、 將陳述副本作為通知的附件以章程規定的方式送給股東。

- (三) 公司如果未將有關會計師事務所的陳述按本款(二)項的規定送出，有關會計師事務所可要求該陳述在股東大會上宣讀，並可以進一步作出申訴。

- (四) 離任的會計師事務所所有權出席以下的會議：

- 1、 其任期應到期的股東大會；
- 2、 為填補因其被解聘而出現空缺的股東大會；及
- 3、 因其主動辭聘而召集的股東大會。

離任的會計師事務所所有權收到上述會議的所有通知或與會議有關的其他信息，並在前述會議上就涉及其作為公司前會計師事務所的事宜發言。

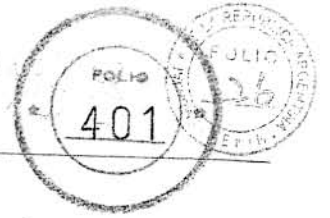

第一百六十四條 公司解聘或者不再續聘會計師事務所，應當事先通知會計師事務所，會計師事務所所有權向股東大會陳述意見。會計師事務所提出辭聘的，應當向股東大會說明公司有無不當情事。

(一) 會計師事務所可以用把辭聘書面通知置於公司法定地址的方式辭去其職務。通知在其置於公司法定地址之日或者通知內註明的較遲的日期生效。該通知應當包括下列陳述：

- 1、 認為其辭聘並不涉及任何應該向公司股東或債權人交代情況的聲明；或
- 2、 任何該等應交代情況的陳述。

(二) 公司收到本條(一)項所指的書面通知的14日內，須將該通知複印件送出給有關主管之機關。如果通知載有本條(一)(2)項提及的陳述，公司應當將該陳述的副本備置於公司，供股東查閱。公司還應將前述陳述副本以郵資已付的郵件寄給每個境外上市外資股股東，受件人地址以股東的名冊登記的地址為準。

(三) 如果會計師事務所的辭職通知載有本條(一)(2)項所提及的陳述，會計師事務所可要求董事會召集臨時股東大會，聽取其就辭職有關情況作出的解釋。

第十八章 通知

第一百六十五條 公司的通知可以下列形式發出：

- (一) 以專人送出；
- (二) 以郵件方式送出；
- (三) 以傳真或電子郵件方式進行；
- (四) 在符合法律、行政法規及公司股票上市地證券交易所的上市規則的前提下，以在公司及香港聯交所指定的網站上發佈方式進行；



- (五) 以公告方式進行；
- (六) 公司或受通知人事先約定或受通知人收到通知後認可的其他形式；
- (七) 公司股票上市地有關監管機構認可或本章程規定的其他形式。

第一

本章程所述「公告」，除文義另有所指外，就向內資股股東發出的公告或按有關規定及本章程須於中國境內發出的公告而言，是指在中國的報刊上刊登公告，有關報刊應當是中國法律、行政法規規定或國務院證券監督管理機構指定的；就向外資股股東發出的公告或按有關規定及本章程須於香港發出的公告而言，該公告必須按有關香港聯交所上市規則要求在指定的香港報章上刊登。

第一

第一百六十六條 除本章程另有規定外，前條規定的發出通知的各種形式，適用於公司召開的股東大會、董事會和監事會的會議通知。

第一百六十七條 公司通知以專人送出的，由被送達人在送達回執上簽名（或蓋章），被送達人簽收日期為送達日期；公司通知以郵件送出的，自交付郵局之日起第48小時為送達日期；公司通知以傳真或電子郵件或網站發佈方式發出的，發出日期為送達日期；公司通知以公告方式送出的，第一次公告刊登日為送達日期。有關公告在符合有關規定的報刊上刊登。

第一

第一百六十八條 若公司股票上市地證券交易所上市規則要求公司以英文本和中文本發送、郵寄、派發、發出、公佈或以其他方式提供公司相關文件，如果公司已作出適當安排以確定其股東是否希望只收取英文本或只收取中文本，以及在適用法律和法規允許的範圍內並根據適用法律和法規，公司可（根據股東說明的意願）向有關股東只發送英文本或只發送中文本。

第一

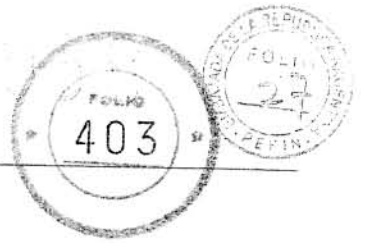

第十九章 公司的合併與分立

- 印後認
規定的
股股東
出的公
憲當是
靠指定
章程須
交所上
形式，
通知。
二簽名
以郵
；公司
出日期
公告刊
刊登。
廷文本
与式提
其股東
月法律
可（根
送中
- 第一百六十九條 公司合併或者分立，應當由公司董事會提出方案，按公司章程規定的程序通過後，依法辦理有關審批手續。反對公司合併、分立方案的股東，有權要求公司或者同意公司合併、分立方案的股東，以公平價格購買其股份。公司合併、分立決議的內容應當作成專門文件，供股東查閱。
- 對境外上市外資股股東，前述文件還應當以郵件方式送達。
- 第一百七十條 公司合併可以採取吸收合併或者新設合併。
- 公司合併，應當由合併各方簽訂合併協議，並編製資產負債表及財產清單。公司應當自作出合併決議之日起10日內通知債權人，並於30日內在報紙上公告。
- 公司合併時，合併各方的債權、債務，由合併後存續的公司或者因合併而新設的公司承繼。
- 第一百七十一條 公司分立，其財產作相應的分割。
- 公司分立，應當編製資產負債表及財產清單。公司應當自作出分立決議之日起10日內通知債權人，並於30日內在報紙上公告。
- 公司分立前的債務由分立後的公司承擔連帶責任。但是，公司分立前與債權人就債務清償達成的書面協議另有約定的除外。
- 第一百七十二條 公司合併或者分立，登記事項發生變更的，應當依法向公司登記機關辦理變更登記；公司解散的，應當依法辦理公司註銷登記；設立新公司的，應當依法辦理公司設立登記。

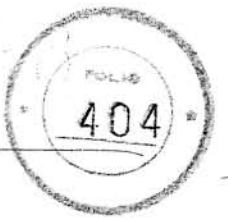

第二十章 公司解散和清算

第-

第一百七十三條 公司因下列原因解散：

- (一) 股東大會特別決議解散；
- (二) 因公司合併或者分立需要解散；
- (三) 依法被吊銷營業執照、責令關閉或者被撤銷；
- (四) 公司違反法律、行政法規被依法責令關閉；
- (五) 公司經營管理發生嚴重困難，繼續存續會使股東利益受到重大損失，通過其他途徑不能解決的，持有公司全部股東表決權10%以上的股東，可以請求人民法院解散公司。

第一百七十四條 公司因本章程第一百七十三條第(一)、(三)、(五)項規定而解散的，應當在解散事由出現之日起15日內成立清算組，開始清算。清算組由董事或者股東大會確定的人員組成。逾期不成立清算組進行清算的，債權人可以申請人民法院指定有關人員組成清算組進行清算。

第-

第一百七十五條 如董事會決定公司進行清算(因公司宣告破產而清算的除外)，應當在為此召集的股東大會的通知中，聲明董事會對公司的狀況已經做了全面的調查，並認為公司可以在清算開始後12個月內全部清償公司債務。

第-

股東大會進行清算的決議通過之後，公司董事會的職權立即終止。

清算組應當遵循股東大會的指示，每年至少向股東大會報告一次清算組的收入和支出，公司的業務和清算的進展，並在清算結束時向股東大會作最後報告。

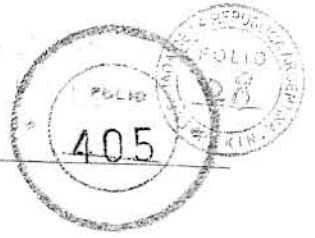

第一百七十六條 清算組在清算期間行使下列職權：

- (一) 清理公司財產，分別編製資產負債表和財產清單；
- (二) 通知、公告債權人；
- (三) 處理與清算有關的公司未了結的業務；
- (四) 清繳所欠稅款以及清算過程中產生的稅款；
- (五) 清理債權、債務；
- (六) 處理公司清償債務後的剩餘財產；
- (七) 代表公司參與民事訴訟活動。

第一百七十七條 清算組應當自成立之日起10日內通知債權人，並於60日內在報紙上公告。債權人應當自接到通知書之日起30日內，未接到通知書的自公告之日起45日內，向清算組申報其債權。

債權人申報債權，應當說明債權的有關事項，並提供證明材料。清算組應當對債權進行登記。

在申報債權期間，清算組不得對債權人進行清償。

第一百七十八條 清算組在清理公司財產、編製資產負債表和財產清單後，應當制定清算方案，並報股東大會或有關主管機關確認。

公司財產按下列順序清償：在分別支付清算費用、職工的工資、社會保險費用和法定補償金，繳納所欠稅款，清償公司債務。

公司財產按前款規定清償後的剩餘財產，由公司股東按其持有的股份的種類和比例分配。

清算期間，公司不得開展新的經營活動。

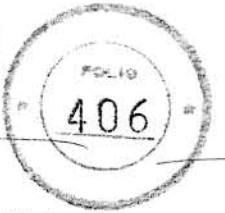

第一百七十九條 清算組在清理公司財產、編製資產負債表和財產清單後，發現公司財產不足清償債務的，應當立即向人民法院申請宣告破產。

公司經人民法院裁定宣告破產後，清算組應當將清算事務移交給人民法院。

第一百八十條 公司清算結束後，清算組應當製作清算報告以及清算期內收支報表和財務帳冊，經中國註冊會計師驗證後，報股東大會或者人民法院確認，並在經股東大會或者人民法院確認之日起30日內，將前述文件報送公司登記機關，申請註銷公司登記，公告公司終止。

第二十一章 公司章程的修訂程序

第一百八十一條 公司根據法律、行政法規及公司章程的規定，可以修改公司章程。

第一百八十二條 修改公司章程應按下列程序：

- (一) 董事會首先通過修改本章程的決議並擬訂章程修正案；
- (二) 董事會召集股東大會，就章程修正案由股東大會進行表決；
- (三) 股東大會特別決議通過章程修正案；
- (四) 公司將經股東大會表決通過的章程修正案報經主管審批機關批准後生效；
- (五) 公司將修改後的公司章程報公司登記機關備案。

第一百八十三條 公司章程的修改，涉及《必備條款》內容的，經國務院授權的公司審批部門和國務院證券委員會批准後生效；涉及公司登記事項的，應當依法辦理變更登記。



第二十二章 爭議的解決

第一百八十四條 本公司遵從下述爭議解決規則：

青單後，
去院申請

青算事務

青算期內
報股東
法院確
申請註

人修改公

章程修正

大會進

經主管

案。

院授權
涉及公

- (一) 凡境外上市外資股股東與公司之間，境外上市外資股股東與公司董事、監事、總經理或者其他高級管理人員之間，境外上市外資股股東與內資股股東之間，基於本章程、《公司法》及其他有關法律、行政法規所規定的權利義務發生的與公司事務有關的爭議或者權利主張，有關當事人應當將此類爭議或者權利主張提交仲裁解決。

前述爭議或者權利主張提交仲裁時，應當是全部權利主張或者爭議整體；所有由於同一事由有訴因的人或者該爭議或權利主張的解決需要其參與的人，如果其身份為公司或公司股東、董事、監事、總經理或者其他高級管理人員，應當服從仲裁。

有關股東界定、股東名冊的爭議，可以不用仲裁方式解決。

- (二) 申請仲裁者可以選擇中國國際經濟貿易仲裁委員會按其仲裁規則進行仲裁，也可以選擇香港國際仲裁中心按其證券仲裁規則進行仲裁。申請仲裁者將爭議或者權利主張提交仲裁後，對方必須在申請者選擇的仲裁機構進行仲裁。

如申請仲裁者選擇香港國際仲裁中心進行仲裁，則任何一方可以按香港國際仲裁中心的證券仲裁規則的規定請求該仲裁在深圳進行。

- (三) 以仲裁方式解決因(一)項所述爭議或者權利主張，適用中華人民共和國(不含香港特別行政區、澳門特別行政區及台灣地區)的法律；但法律、行政法規另有規定的除外。

- (四) 仲裁機構作出的裁決是終局裁決，對各方均具有約束力。

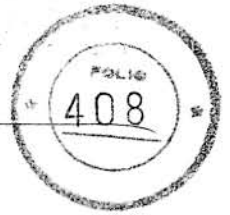

第二十三章 附則

- 第一百八十五條 公司的信息屬於國家機密、商業機密或者香港聯交所認知的其他情形，履行相關披露義務可能導致公司違反國家有關保密的法律法規或損害公司利益的，公司可以豁免披露或履行相關義務。
- 第一百八十六條 本章程中所稱「會計師事務所」的含義與「核數師」相同。
- 本章程所稱「實際控制人」是指雖然不是公司的股東，但通過投資關係、協議或其他安排，能夠實際支配公司行為的人。
- 本章程所稱「以上」、「以內」、「以下」，都含本數；「超過」、「以外」不含本數。
- 第一百八十七條 公司章程以中文書寫，其他任何語種的章程與公司章程有歧義時，以中文版章程為準。
- 第一百八十八條 本章程的解釋權屬於公司董事會，本章程未盡事宜，由董事會提交股東大會決議通過。



Nota: Los Estatutos Sociales de la Compañía se aprobaron en la segunda reunión extraordinaria de la Junta General de Accionistas celebrada en el día 25 de junio de 2011. Posteriormente se aprobaron enmiendas de dicho documento, que se anunció tras la cotización de acciones H de la Compañía en Hong Kong y entró en vigor el 21 de diciembre de 2012, fecha de negociación de acciones H de la Compañía en Hong Kong. En la Junta General de Accionistas de la Compañía 2012, que se celebró el día 17 de junio de 2013, los accionistas aprobaron las enmiendas de los Estatutos Sociales.

所認可
國家有
免披露

目同。

，但通
行為的

或：「超

章程有

，由董

中国机械设备工程股份有限公司
China Machinery Engineering Corporation
(una sociedad anónima de la República Popular China con responsabilidad limitada)
(Código de Valores: 1829)

Estatutos Sociales

2013

*sólo para identificación

中国私权... 公证...



13404709-001 1/1 ⑤

阿根廷 EDC

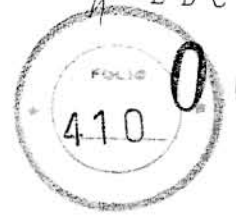

0088

公 证 书

中华人民共和国北京市长安公证处



中国机械设备工程股份有限公司
China Machinery Engineering Corporation

No. 178, Guang anmenwai Street, Beijing 100055, China
Email: cmec@mail.cmec.com Tel: (86-10) 63451188

http://www.cmec.com
Fax: (86-10) 63261865

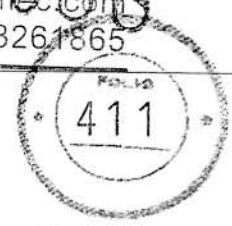

声明
Sworn Statement

本人张淳，作为中国机械设备工程股份有限公司的总裁，根据中国机械设备工程股份有限公司对我的授权，声明如下：

ZHANG CHUN, AS THE PRESIDENT OF CHINA MACHINERY ENGINEERING CORPORATION, IN MY CAPACITY OF ATTORNEY WITH ENOUGH POWER OF CMEC FOR THIS ACT, DECLARE UNDER OATH THE FOLLOWING:

中国机械设备工程股份有限公司国有控股性质说明
Illustration of State-owned holding for CHINA MACHINERY ENGINEERING CORPORATION





0088
 中国机械设备工程股份有限公司
 China Machinery Engineering Corporation



No. 178, Guang anmenwai Street, Beijing 100055, China http://www.cmec.com
 Email: cmec@mail.cmec.com Tel: (86-10) 63451188 Fax: (86-10) 63261865

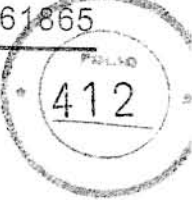

说明/Remark:

1. 中华人民共和国国务院 (简称国务院), 即中央人民政府, 是最高国家权力机关的执行机关, 是最高国家行政机关。

The State Council of the People's Republic of China (The State Council), namely the Central People's Government, is the highest executive organ of State Power, as well as the highest organ of State administration.

2. 国务院国有资产管理委员会 (简称国资委), 是国务院下设的直属特设机构, 负责对国有资产进行监督管理。

The State-owned Assets Supervision and Administration Commission of the State Council (SASAC) is a Special Organization directly under the State Council. SASAC is responsible for the supervision and management of state-owned assets.

3. 中国机械工业集团有限公司, 依照中国法律成立于1997年, 是一家受国资委监督, 管理的中央企业 (参见国资委网站公布的央企名录 <http://www.sasac.gov.cn/n2963340/n2971121/n4956567/4956583.html>), 英文名简称 SINOMACH。

China National Machinery Industry with the short name SINOMACH, which was established in the year of 1997 and registered under the law of P.R.C., is a state-owned Enterprises List in SASAC website (<http://www.sasac.gov.cn/n2963340/n2971121/n4956567/4956583.html>).

4. 中国机械设备工程股份有限公司, 原名中国机械设备进出口总公司, 是一家注册在中国, 由中国机械工业集团有限公司控股, 并于2012年于中国香港上市的股份有限公司, 英文名为 China Machinery Engineering Corporation, 英文简称为 CMEC。

China Machinery Engineering Corporation, registered under the law of P.R.C., is a state-owned holding stock company held by SINOMACH. CMEC was listed on the Stock Exchange of HONG KONG in China in 2012. In 2012, the English name of CMEC was changed from "China National Machinery and Equipment Import and Export Corporation" to "China Machinery Engineering Corporation", and kept the short name as "CMEC".

Signature: 张淳

Name: ZHANG Chun

Title: President of CMEC

Date: 2013-12-02

DECLARACIÓN JURADA

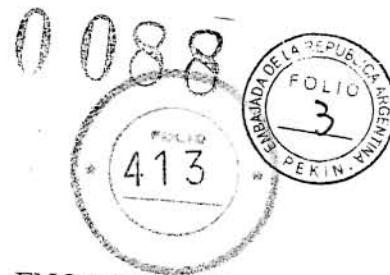

ZHANG CHUN, PRESIDENTE DE CHINA MACHINERY ENGINEERING CORPORATION (CMEC), APODERADA POR CMEC PARA ESTE ACTO, DECLARO BAJO JURAMENTO LO SIGUIENTE:

ILUSTACIÓN DE CHINA MACHINERY ENGINEERING CORPORATION DE PROPIEDAD ESTATAL



OBSERVACIONES:

1. El Consejo de Estado de la República Popular de China (Consejo de Estado), o sea, el Gobierno Central del Pueblo, es el órgano ejecutivo supremo del Poder de Estado, así como órgano administrativo supremo de Estado.
2. La Comisión de Supervisión y Administración de propiedad estatal del Consejo de Estado (SASAC) es una organización especial directamente bajo el Consejo de Estado. SASAC es responsable de la supervisión y la gestión de los bienes estatales.
3. China National Machinery Industry (SINOMACH), establecida en el año 1997 y registrada en conformidad con la ley de la República Popular China, es una empresa de propiedad estatal bajo la supervisión y administración de SASAC (ver <http://www.sasac.gov.cn/n2963340/n2971121/n4956567/4956583.html>).

0088

4. China Machinery Engineering Corporation, registrada en conformidad con la ley de la República Popular China, es una sociedad anónima de propiedad estatal de SINOMACH. CMEC comenzó a cotizar en la Bolsa de Valores de Hong Kong en 2012. En el mismo año, el nombre completo en inglés de CMEC fue cambiado de "China National Machinery and Equipment Import and Export Corporation" a "China Machinery Engineering Corporation", y la abreviatura mantuvo lo mismo.



FIRMA: _____
NOMBRE Y APELLIDO: ZHANG CHUN
TÍTULO: PRESIDENTE DE CMEC
FECHA: _____

公 证 书

0088



(2013)京长安外经证字第8264号

申请人：中国机械设备工程股份有限公司

住所：北京市西城区广安门外大街178号

法定代表人：孙柏，男，一九五七年十月三日出生，公民身份号码：220104195710031333

公证事项：签名

兹证明前面的《声明》上中国机械设备工程股份有限公司的总裁张淳的签名属实。

中华人民共和国北京市长安公证处

公 证 员

张 淳 恒

二〇一三年十二月十日



张 淳 恒

1139143736

ACTA NOTARIAL

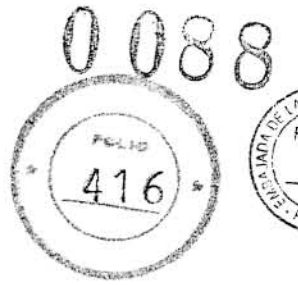

(2013) J.C.A.W.J.Z.Zi N.º 8264

Solicitante: China Machinery Engineering Corporation.

Domicilio: Guang'anmenwaidajie Nº178, Distrito de Xicheng, Municipio de Beijing.

Representante Legal: Sun Bai, de sexo masculino, DNI.N.º: 220104195710031333.

Contenido notarial: firma.

Se certifica por la presente que es verídica la firma de Zhang Chun, Presidente de China Machinery Engineering Corporation, en la "DECLARACIÓN JURADA" antecedente.

Notaría Chang'an del Municipio de Beijing,

República Popular China

Notario: Jiang Duheng

El 10 de diciembre de 2013

1139143737

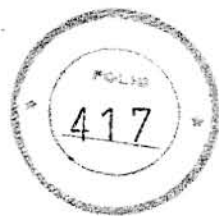

认字第13404709-001号

兹证明前面文书上公证处的印章和公证员蒋笃恒的签名（印章）属实。



中华人民共和国外交部
等秘书
二月十三日

Handwritten signature



LEGALIZACION F.S. Nº 4794024
PEKIN (RPC) 16 DIC 2013

Handwritten signature

Gonzalo Javier SABATE
Consul Graf. Adjunto
Beijing-R.P. China

ECHIN 17632 /2013

0088



REPÚBLICA ARGENTINA

MINISTERIO de RELACIONES EXTERIORES COMERCIO INTERNACIONAL Y CULTO

Sello ovalado cruzado

En virtud de las facultades conferidas por el Art. 226 del Reglamento Consular (Decreto 8714/1963):

TIPO DE DOCUMENTO: DECLARACION JURADA

CANTIDAD DE FOJAS QUE INTEGRAN EL DOCUMENTO: 6
POR CORRESPONDERSE CON LA OBRANTE EN LOS REGISTROS DE ESTA REPRESENTACION CONSULAR SE LEGALIZA LA FIRMA DE: PENG, haiqiu

CARGO/CALIDAD EN LA QUE ACTUA: PRIMER SECRETARIO, CANCELLERIA REPUBLICA POPULAR CHINA

FECHA OBRANTE EN EL SELLO: 13/12/2013
N° (SI OBRA EN SELLO): 13404709-001

PERSONAS INTERVINIENTES:
RECURRENTE: CHINA MACHINERY ENGINEERING CORPORATION

REPRESENTACION CONSULAR ARGENTINA QUE INTERVIENE: Sección Consular de la Embajada Argentina en BEIJING

FECHA: 16/12/2013

Sello ovalado cruzado

Sello y Firma del funcionario

Gonzalo Javier SABATE
Cónsul Gral. Adjunto
Beijing- R.P. China

N° DE ORDEN: ECHIN 17632/2013
N° ARANCEL: 6.4.3
DERECHOS PERCIBIDOS: CNY 372.00

Art. 229 del Reglamento Consular (Decreto N° 8714/1963 modificado por el Decreto N° 1629/2001: "Los documentos extranjeros autenticados en la forma establecida en el presente Reglamento harán fe en territorio nacional, sin necesidad de su posterior legalización ante otra autoridad argentina"



0088



ANNEX 2.1. TECHNICAL SPECIFICATIONS OF THE RAILROAD COMPONENTS

TECHNICAL SPECIFICATIONS FOR RAILS

ATC. L01.T1.001 (E2)

1. CONTENTS

Description: T-section UIC54 rail

Safety level: Class A (Safety material-Safety level:100)

2. TECHNICAL DOCUMENTS

All the following technical documents are general requirements on manufacture and control under this Technical Specification.

Main technical parameters:

- 2.0.1 Rail type: UIC 54 E1
- 2.0.2 Class: X
- 2.0.3 Steel grade: R 260
- 2.0.4 Unit weight (per meter): 54.77 Kg
- 2.0.5 Length: 25m undrilled
- 2.0.6 Brinell hardness: 260-300 HB

Special standard:

- 2.1.1 EN 13674-1 / 2011 T-section rail.

General standard:

- 2.2.1 EN 10163-1 Surface condition
- 2.2.2 EN 10247 Microscopic analysis – non - metallic inclusions
- 2.2.3 CEN/TR 10261 Chemical analysis
- 2.2.4 EN 10276-1 O2 determination
- 2.2.5 EN ISO 6506-1 Brinell hardness
- 2.2.6 EN ISO 6892-1 Mechanical characteristics
- 2.2.7 EN ISO 14248 Sample preparation
- 2.2.8 ISO 1099 Fatigue test
- 2.2.9 ISO 4968 Bauman test
- 2.2.10 ASTM E399
- 2.2.11 Reference standard





3. ACCEPTANCE TESTING

Acceptance Testing shall be conducted in accordance with relative technical documents. The following technical documents should be provided for testing and acceptance:

- 3.0.1 Anti-tensile test Chapter 8.7 - EN 13674-1/2011
- 3.0.2 Elongation test Chapter 8.7 - EN 13674-1/2011
- 3.0.3 Fatigue test Chapter 8.3 and 8.4- EN 13674-1/2011
- 3.0.4 Residual stress test Chapter 8.5- EN 13674-1/2011
- 3.0.5 Hardness variation test Chapter 8.6- EN 13674-1/2011
- 3.0.6 Bauman test Chapter 8.8- EN 13674-1/2011
- 3.0.7 Diversity analysis Chapter 9- EN 13674-1/2011
- 3.0.8 Chemical analysis Table 5a and table5b - EN 13674-1/2011
- 3.0.9 Size control Table 7 - EN 13674-1/2011
- 3.0.10 Straightening Table 8 - EN 13674-1/2011
- 3.0.11 Ultrasonic testing Chapter 9- EN 13674-1/2011

4. PARTICULAR NOTES

- 4.1 The supplier shall comply with special standards of products (EN 13674-1/2011). The control and testing records provided by the foresaid supplier shall be the original version with signature of its responsible person. The documents shall be presented along with delivery of the corresponding batch of products.
- 4.2 Testing shall be conducted in the lab which can meet the requirements of Article 8.6.1 of EN 13674-1/2011.
- 4.3 The Principal or his authorized agent has the right to test all the production details or reasonably verify during the production of rail. The manufacturer should provide corresponding testing tools and necessary technical personnel at any time.
 - Testing is conducted by the manufacturer, and the products cannot be delivered until the testing is approved by the Principal.
 - Any responsibility or obligation of the manufacturer will not be relieved when the testing records fulfill the requirements.
 - The gauge which is necessary for controlling size of the products shall be produced by the manufacturer at its own cost, and it should be examined and approved by the Principal. Before delivery of the rail, the manufacturer shall provide to the Principal 2 sets of gauges free of charge for the Principal's necessary examination.



0088

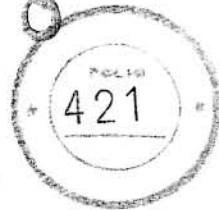

- The size of gauge should fulfill the requirements of annex E of EN 13674-1/2011.
- After above 2 sets of gauges have been examined and approved by the Principal, they will be kept by the Principal.
- The acceptance tests shall be carried out in accordance with Article 9.1 of EN 13674-1/2011 and notice given to "BelgranoCargas y Logística S.A."
- The chemical composition of the material shall be analyzed by the manufacturer, the analysis results shall notice the Principal. The Principal can verify if the chemical composition of steel is in accordance with the provisions of the contract specification. The Principal can choose to witness the laboratory analysis in factory.
- Subject to prior consent of the manufacturer, the Principal can analyze the represented samples from 20 consecutive samples in another laboratory.
- The manufacturer will provide a mill certificate concerning all the chemical tests showing the elements specified in table 5 a) and 5 b) of the standard EN 13674-1/2011.
- If any analysis fails to meet the specified requirements, the batch of rails will be rejected.
- After the rolling process is completed, all rails will be detected by ultrasonic testing as per article 9.4 of EN 13674-1/2011.
- All the details such as the metallurgical and technical characteristics of the rails shall be submitted.

5. MARKING

In addition to the marking requirements of section 7.4.1 and 7.4.2 of EN 13674-1/2011, each rail should be identified in the form of hot stamping code with the name of the company "BCyL".

6. PACKING AND TRANSPORTATION

The products shall be packed and protected in accordance with the following instructions:

Rails shall be packed ready for ocean transportation, bundled in a group of five by five iron hoops distributed evenly with the rail bottom out. The way of packing by the manufacturer shall be subject to the prior approval of the "BelgranoCargas y Logística S.A."

Each packing shall be marked with the following information:

- Name of the Principal
- Place of delivery



- Loading port
- Rail type identification (cross section and class)

The manufacturer shall guarantee that the rail is free from any defects not found during the production and acceptance tests within the time stipulated in the contract.

If any fracture or defect is found during this period, such rails can be replaced, and defected rails shall be sent back to the manufacturer's laboratory for testing.

In the case that the manufacturing defects are confirmed or verified by laboratory tests, such rail must be replaced by the manufacturer at its own cost.

The manufacturer shall ensure that the Principal is free from any claim for licenses or patent fees.



0088

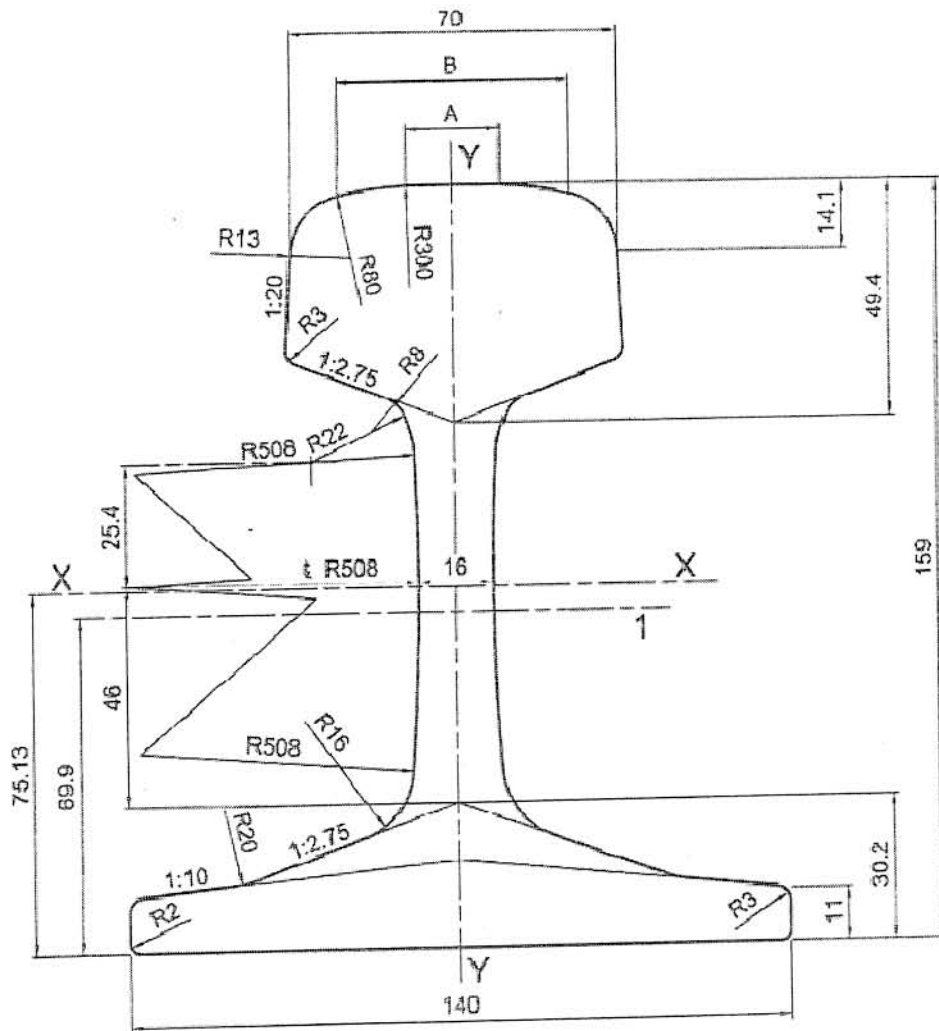
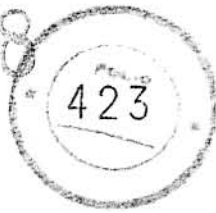

Key

1 centre line of branding

| | | |
|----------------------------|---------------|-----------------|
| cross-sectional area | : 69.77 | cm ² |
| mass per metre | : 54.77 | kg/m |
| moment of inertia x-x axis | : 2 337.9 | cm ⁴ |
| section modulus - Head | : 278.7 | cm ³ |
| section modulus - Base | : 311.2 | cm ³ |
| moment of inertia y-y axis | : 419.2 | cm ⁴ |
| section modulus y-y axis | : 59.9 | cm ³ |
| indicative dimensions: | A = 20.024 mm | |
| | B = 49.727 mm | |

Figure A.15 — Rail profile 54E1

0088



TECHNICAL SPECIFICATIONS FOR MONOBLOCK CONCRETE SLEEPER PRODUCTION

CONTENTS

1. TYPE
2. INSERTS
3. NORMS
4. CURING
5. QUALITY OF MATERIAL
6. MARKING
7. STORE AND TRANSPORTATION
8. TESTS
9. DOCUMENTATION
10. GUARANTEE
11. TESTS OF MATERIAL QUALITY
12. REQUIRED TESTS FOR DESIGN APPROVAL
13. REQUIREMENTS OF SLEEPERS WITH VOSSLOH FASTENING SYSTEM
14. PLAN TYPE FOR REFERENCE

1. TYPE

The sleepers should be prestressed concrete monoblock ones for nominal wide gauge of 1676 mm and 1000mm with 54 E1 rails and Vossloh W21 elastic fasteners.

2. INSERTS

ADIF 1676mm sleepers:

The inserts embedded in the sleepers, certificated by Vossloh with their correspondent guarantee, will be provided by ADIF to the Contractor.

The other sleepers:

The necessary VosslohW21 fastening system pre-inserts will be provided by the Contractor.

3. NORMS

The final length and section of the sleepers should be calculated and designed according to specifications ALAF 5-022 "Norm for monoblock concrete sleeper" and AREMA "American Railway Engineering and Maintenance-of-Way Association". The producer should present in its methodology the documents which can show that the technical feature of the sleeper meets the requirements of the mentioned norms.

The parameters of the wide gauge sleepers (1676mm)are:

- Train type 45 carriages of 3100 tons



0088



- Wheel diameter: 953mm
- Maximum axle load and design speed: 22 tons for 160km/h and 25tons for 120km/h
- Gauge: 1676mm
- Minimum radius of curve: 300m
- Rail bottom cant: 1:40
- Sleepers per kilometer: 1540
- Rail type and quality: UIC 54 E1
- Fastener feature: Vossloh W21
- Minimum length of concrete sleeper: 2.60m
- Minimum weight of sleeper: 280kg
- Minimum quality of prestressed steel of each piece of sleeper: 5.60kg
- Concrete feature: fck: 50 Mpa
- Reinforcement: 12 steel wires with diameter of 6mm and allowable stress of 175 Kgf/mm² (low-relaxation)

The parameters of the meter gauge sleepers (1000mm) are:

- Train type 45 carriages of 3,100 tons.
- Wheel diameter: 762 mm.
- Maximum axle load: 22 tons.
- Maximum design speed: 90 km / h.
- Gauge: 1,000 mm
- Minimum radius of curve: 300 m.
- Rail bottom cant 1:40.
- Sleepers per kilometer: 1540.
- Rail type and quality: UIC 54 E1.
- Fastener feature: double elastic.
- Maximum length of concrete sleeper: 2400 mm
- Minimum length of concrete sleeper: 1900mm
- Minimum weight of sleeper: 200 kg

Minimum quality of prestressed steel of each piece of sleeper: 4.80 kg

4. CURING

After the casting and molding, the curing process should be started. Concrete temperature should not be lower than 10°. During the natural curing, the concrete temperature should not be higher than 32° during the first 3 hours and 40° during the first 4 hours. In heat-accelerated curing, the temperature gradient must not exceed 19.4° per hour and the curing temperature in concrete should not exceed 60°, except when the manufacturer can show that the materials have a satisfactory long-time durability at 70° in this case.



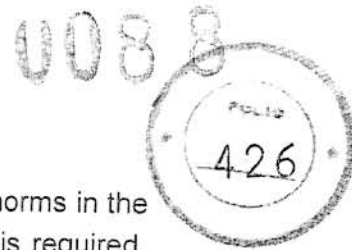

5. QUALITY OF MATERIAL

The quality of the materials should meet the requirements of the current norms in the country of origin. The submission of the norms and the results of tests is required, and all these documents should be translated into the Spanish language by the Contractor.

The Argentine norms IRAM (Institute of Material Rationalization of Argentina) for quality of prestressed concrete materials are mentioned as references in Annex 1:

- Water
- Fine aggregate
- Coarse aggregate
- Cement
- Steel
- Additives

6. MARKING

The sleepers should be marked by mold in low relief with the following indications:

- Symbol of the manufacturer
- The logo of "ADIF" for ADIF sleepers and the logo of "BCyL" for the other sleepers
- Year of production, indicated by numbers (for example, 2013 will be indicated as 2013)

The marking must not affect the use of the sleepers.

7. STORAGE AND TRANSPORTATION

The storage and transportation of the sleepers should be carried out in accordance with the Norms ALAF 5-022 and AREMA.

Stacking more than 15 sleepers at a time is not allowed. Between every two stories of sleeper there should be a softwood-made interposition with rectangular section and minimum thickness of 0.04m. Identical wedges should be used when the sleepers are loaded on wagons if several stories of sleepers should be stacked up.

Precautionary measures will be taken during the storage of the sleepers in order that the products won't suffer from any condition out of the design scope.

8. TESTS

The fabrication of sleepers should be certificated by a Chinese university. The tests for monoblock concrete sleepers will be referred as the Norm AREMA "American" 

0088

Railway Engineering and Maintenance-of-Way Association" (Vol. 1-Chapter 30-Part 2 "Evaluative Tests for Tie Systems").

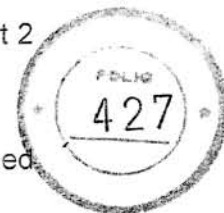

The required tests are specified in Annex 2. The tolerances come from the mentioned norms.

The Principal has the right to carry out the sampling and testing in local universities of Argentina of the sleepers from every batch of products.

Besides the AREMA norm (Vol.1-Chapter 30- Part 2), the tests of pre-inserts should comply with the Annex 2-Required Tests for Design Approval and the Annex 3-Requirements of Sleepers with Vossloh Fastening System.

9. DOCUMENTATION

Regarding the documentation, it is required to submit the precedents of the factory, wherever its place of origin was, and the technical requirements of the sleepers produced in the last 5 years.

All the documentation should be in Spanish. The Chinese norms should be translated into the Spanish language by the Contractor.

10. GUARANTEE

The concrete sleeper and its inserts will be guaranteed at least to December 31 N+G. N means the year of production without design and/or fabrication defects, and it is independent of the results of inspection carried out by the buyer during the reception. G is the number of years established in the Contract.

11. TESTS OF MATERIAL QUALITY

PORTLAND CEMENT

- Chemical analyses and physical tests in accordance with Norm IRAM 50000
- Compression and flexion resistance. Norm IRAM 1622
 - Test of 6 samples, 7 and 28 days
 - Test of 3 additional samples of any time
- Complete physical test. Norm IRAM 50000
- Sulfate resistance. Portland cement with additives. Norm IRAM 1635
- Potential alkali-aggregate reactivity. Norm IRAM 1637
 - Every 3 or more tests (value per test)
- Studies of alkali-carbonate reaction. Norm IRAM 1700
- Studies of alkali-silica reaction. Norm IRAM 1700
- Study of alkali-silica reaction in aggregates. Norm IRAM 1674



0088

**WATER FOR MORTAR AND CONCRETE MIXING**

Norm IRAM 1601

Minimum quantity of the sample: 10 lts.

Setting time

- Compression resistance. Test of 6 samples of 4×4×16cm 28 days
- Complete physical and chemical test (comparative with interpretations)
- Chemical analysis

AGGREGATES FOR MORTAR AND CONCRETE

- Abrasion, machine los Angeles, norm IRAM 1532
- Durability by sodium sulfate attack. Norm IRAM 1525
- Organic matter. Norm IRAM 1512
- Durability by immersion in ethylene glycol. Norm IRAM 1519
- Granulometry. Norm IRAM 1505
- Dust (material which can pass the sieve IRAM N° 200). Norm IRAM 1540
- Carbonaceous material. Norm IRAM 1649/1517
- Soft and decomposed particles. Norm IRAM 1644
- Density and water absorption
- Coarse aggregate. Norm IRAM 1533
- Fine aggregate. Norm IRAM 1520
- Unit volume weight. Norm IRAM 1548
- Soluble salts. Norm IRAM 1647
- Chlorides
- Sulfates. Norm IRAM 1647

STEEL

- Wires for prestressed concrete. Norm IRAM-IAS U 500-517
- Low relaxation steel
- Quality certificate

CONCRETE ADDITIVES

- Air entraining. Norm IRAM 1663
- Concrete setting retarding. Norm IRAM 1663
- Plasticizers o super-plasticizers. Norm IRAM 1663

12. REQUIRED TESTS FOR DESIGN APPROVAL

- Positive bending moment test on rail supporter
- Negative bending moment test on rail supporter
- Positive bending moment test – Center
- Negative bending moment test – Center
- Fatigue flexion test
- Vertical load test on rail supporter
- Anti-off test of pre-inserts Rail-sleeper fastening system resistance test



0088



13. REQUIREMENTS FOR SLEEPERS WITH VOSSLOH FASTENING SYSTEM

The measurements in the table below is for reference (which is originally for 1000mm gauge railway sleeper), the exact measurements of the fastening system and final requirements from fastening system for sleepers should be submitted to the Contractor by Vossloh.

| Inspection Report (Part 1) | | | vossloh Fastening Systems | |
|---------------------------------|--|-------------------|------------------------------|-----------------------|
| Concrete sleeper for System ... | | | | |
| Drawing-Nr. | | Project | Circle-Nr. | |
| Manufacturer: DHASA ADIF | | Quantity and unit | Date: 06 08 2013 | |
| Nr. | Measurement | Setpoint | Actual value E-600 | Actual value F-624 |
| 01 | Outer shoulder distance | | 1365 | 1366 |
| 02 | Bead distance (l) | | 288.4 | 287.8 |
| 02 | Bead distance (r) | | 288.5 | 288.5 |
| 03 | Shoulder angle (left/ fieldside) | | 30.5 | 29.5 |
| 03 | Shoulder angle (left/ gaugeside) ... | | 30.5 | 30.8 |
| 03 | Shoulder angle (right/ fieldside) ... | | 29.9 | 30.9 |
| 03 | Shoulder angle (right/ gaugeside) | | 30.7 | 29.6 |
| 04 | Dowel distance (left/ fieldside) | | 61.6 | 61.5 |
| 04 | Dowel distance (left/ gaugeside) | | 61 | 60.9 |
| 04 | Dowel distance (right/ fieldside) | | 60.9 | 60.2 |
| 04 | Dowel distance (right/ gaugeside) | | 61.7 | 60.4 |
| 05 | Dowel angle (left/ fieldside) | | 5.2 | 5.3 |
| 05 | Dowel angle (left/ gaugeside) | | 5 | 4.8 |
| 05 | Dowel angle (right/ fieldside) | | 4.4 | 5.1 |
| 05 | Dowel angle (right/ gaugeside) | | 5.2 | 4.8 |

0088



Inspection Report (Part 2) **vossloh**
Fastening Systems

Concrete sleeper for System ...

| Drawing-Nr. | | Project | Order-Nr. | |
|---------------------------------|--|--|------------------|---------------------------------|
| Nr. | Measurement | Setpoint | Actual value | Actual value |
| 06 | Dowel angle (alongside rail) (left fieldside) | | 0.1 | 0.9 |
| 06 | Dowel angle (alongside rail) (left gaugeside) | | 0.7 | 0 |
| 06 | Dowel angle (alongside rail) (right fieldside) | | 0.1 | 0 |
| 06 | Dowel angle (alongside rail) (right gaugeside) | | 0.2 | 0.1 |
| 07 | Inclination (left) | | 1.1° | 0.9° |
| 07 | Inclination (right) | | 1.6° | 1.7° |
| 08 | Bead deepness (left fieldside) | | 14.5 | 14.8 |
| 08 | Bead deepness (left gaugeside) | | 15 | 14.8 |
| 08 | Bead deepness (right fieldside) | | 15 | 14.8 |
| 08 | Bead deepness (right gaugeside) | | 15 | 14.9 |
| 09 | Dowel position | | - | - |
| 10 | Length of the rail seat | | 102 | 103 |
| 11 | Identification marking | | | |
| 12 | Surface | | | |
| Notice | | | | |
| <input type="checkbox"/> Accept | | <input type="checkbox"/> Accept with restriction | | <input type="checkbox"/> Reject |
| Vossloh Fastening Systems GmbH | | | Date / Signature | |

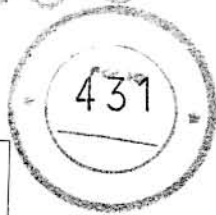

14. PLAN TYPE FOR REFERENCE

The PLAN TYPE of monoblock concrete sleeper is attached below for reference.

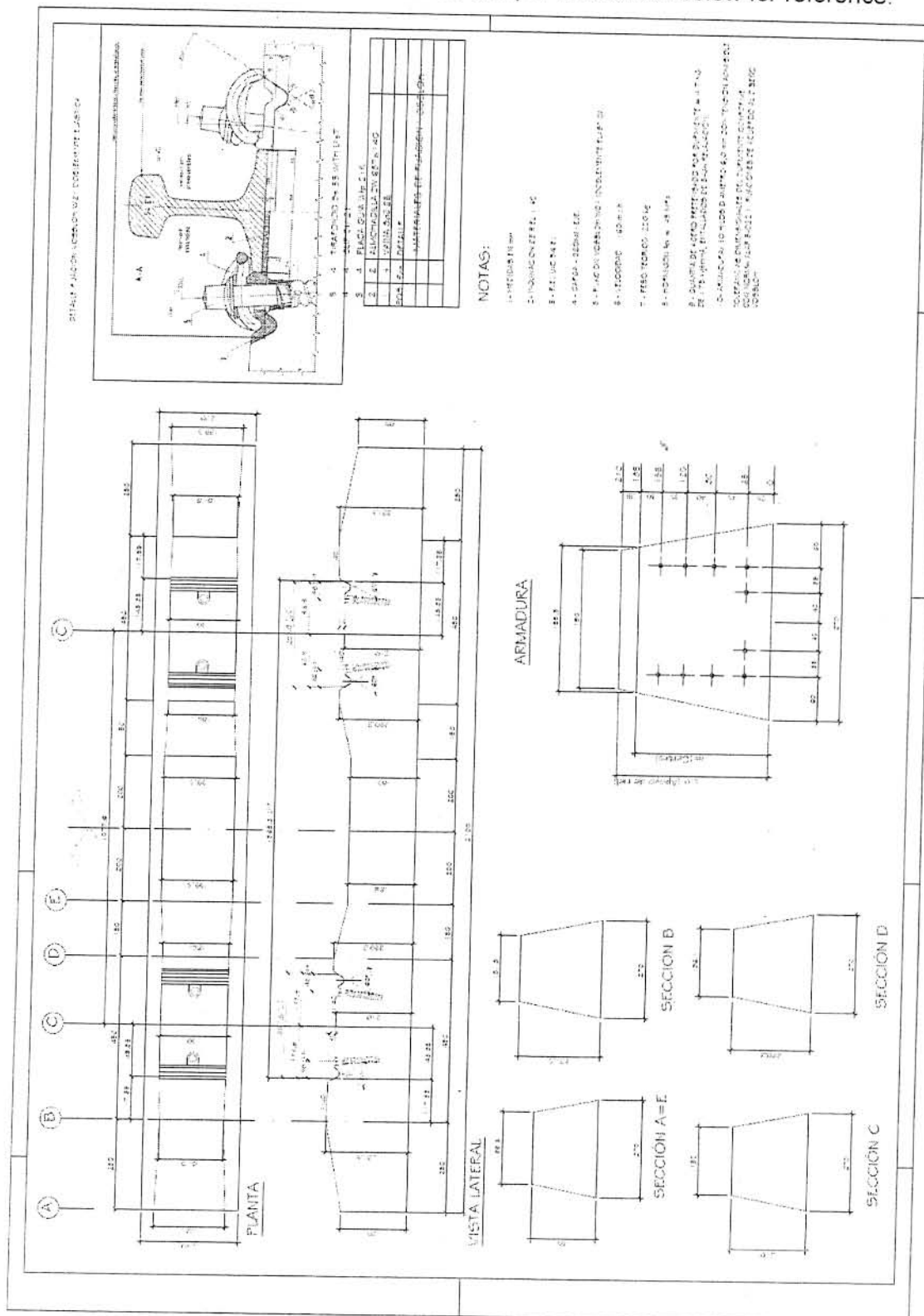

0088

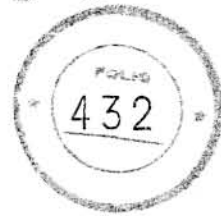

**TECHNICAL SPECIFICATIONS
FOR ELASTIC FASTENERS OF CONCRETE SLEEPERS
ATC. L01.T1.010 (E2)**

1. CONTENTS

Description

Double elastic clip fastening system type: VOSSLOH SKL 21 / W21.

Application

Applicable to fasteners of prestressed concrete sleepers

Safety level: level A (safety material-safety level: 100)

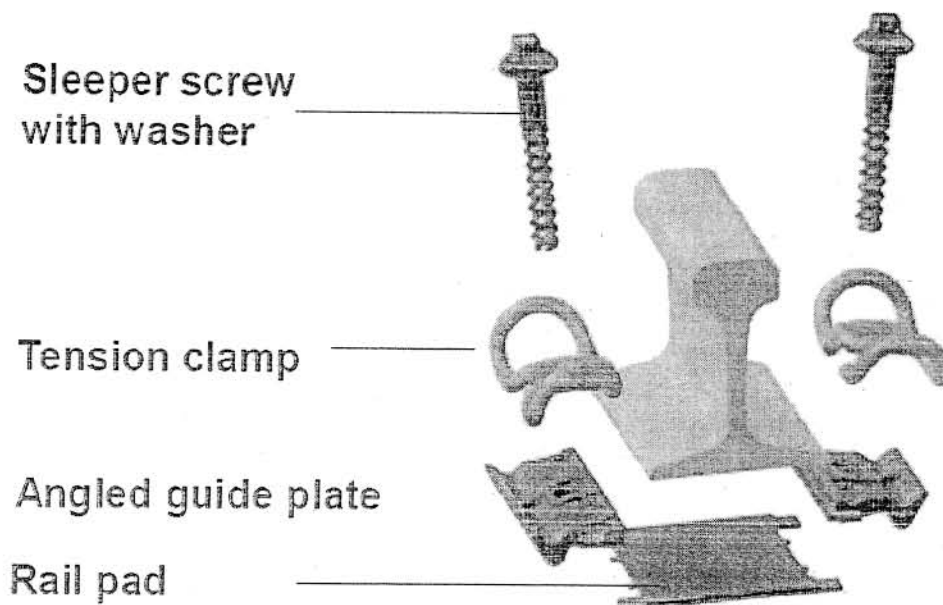

2. TECHNICAL DOCUMENTS

All the technical documents are general requirements on manufacture and control under this Technical Specification

General technical parameters

- | | |
|-------|-----------------------------------|
| 2.0.1 | Vossloh SKL 21 / W21 |
| 2.0.2 | Maximum axle load: 25 t |
| 2.0.3 | Maximum design speed: 90 Km/h. |
| 2.0.4 | Gauge: 1676, 1435, 1000 mm |
| 2.0.5 | Minimum radius of curve: 300 m |
| 2.0.6 | Gradient: 1 : 40 |
| 2.0.7 | Sleeper density (pieces/km): 1660 |

0088



2.0.8 Steel type: UIC 54 E1

Special standards

2.1.1 EN13481-2

Testing standards

2.2.1 EN 13146 -1

2.2.2 EN 13146 -2

2.2.3 EN 13146 -3

2.2.4 EN 13146 -4

2.2.5 EN 13146 -5

2.2.6 EN 13146 -6

2.2.7 EN 13146 -7

2.2.8 EN 13146 -8

2.2.9 EN 13130 -1

2.2.10 ALAF 5-031

General standards

2.3.1 ISO 7888

2.3.2 ISO 9227

2.3.3 ERRI D170 /RP5

2.3.4 Reference standards

3. ACCEPTANCE TESTING

Acceptance testing shall be conducted in accordance with relative technical documents. The following technical documents will be provided for testing and acceptance which are subject to VOSSLOH quality control procedures :

3.0.1 Longitudinal displacement resistance test

3.0.2 Torsion resistance test

3.0.3 Dynamic tilt load test

3.0.4 Resistance test

3.0.5 Environment test

3.0.6 Toe load testing

3.0.7 Shock attenuation test



0088



4. PARTICULAR NOTES

- 4.1. The supplier shall comply with special standards of products (EN 13481-2). The control and testing records provided by the foresaid supplier shall be the original version with signature of its responsible person. The documents shall be presented along with delivery of the corresponding batch of products.
- 4.2. Testing shall be conducted as described in the reference standards of ALAF 5-031 or VOSSLOH corporate standards .

5. MARKING

The products shall be marked in accordance with the requirements of Article 4.11 of ALAF 5-031.

6. PACKING AND TRANSPORTATION

Packing and transportation of the products shall comply with the following instructions.

6.1 Exterior protection

The products shall be protected by plastic exterior.

6.2 Packing and transportation

Complete sets of the products shall be packed and transported in stackable cases.

A handwritten mark or signature in the bottom right corner of the page, consisting of a stylized, cursive-like shape.

A small handwritten mark or signature in the bottom left corner of the page, resembling a stylized 'X' or a similar symbol.

0088



ANNEX 2.2. TECHNICAL SPECIFICATIONS FOR ROLLING STOCK

TECHNICAL SPECIFICATIONS FOR LOCOMOTIVES

CONTENTS

1 General Specification

- 1.1 Service Condition
- 1.2 General Technical Data
- 1.3 Diesel Engine
- 1.4 Electric System
- 1.5 Brake System
- 1.6 Bogie
- 1.7 Carbody
- 1.8 Interior Cab Facilities

TECHNICAL SPECIFICATION

The charge locomotive is double cabs, inside corridor and side wall loading structure, on which a series of advanced and reliable technology and components including MTU16V4000R43 type diesel engine, AC-DC transmission system and Knorr-Bremse CCBII, CCB26 Air brake system are adopted. The locomotive has dynamic brake, self-load test, microprocessor control and multiple unit functions. The locomotive can completely meet the specific operating requirements and condition of Argentina railways.

1 General Specification

1.1 Service Condition

Track Conditions

Gauge of track 1676 mm

Loading gauge (service order clearance) Meet the requirements of NEFA 604

Min. radius of curve 200 m (main line) 100m (Max. speed of the locomotive is under 12~15km/h on the siding line)

Ambient Conditions

Max. altitude above the sea ≤ 1500 m

Ambient temperature $-15 \square \sim +45 \square$

Max. relative humidity at sea level 90~100%

Climatic conditions Ocean climatic, rainy and snowy, dusty

1.2 General Technical Data

Model designation:

Transmission mode AC-DC

Scope of application Charge transportation

Engine service power 2200kW

0088

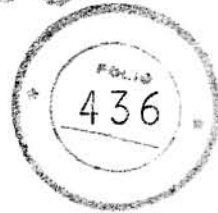

Axle arrangement Co-Co
 Wheel diameter 1050 mm
 Locomotive weight (with full supplies) \leq 120 t
 Axle load 20t
 Gear ratio specified 92:19 (**gear ratio requested: 63:14**).
 Height of coupler center from the top of rail 900 mm
 Fuel tank capacity 5000 L
 Cooling water capacity 800 L
 Sand capacity 400 kg
 Oil storage 400 L
 Speed (wheel half worn 1015 mm):
 Max. service speed 100 km/h
 Continuous speed 22,5 km/h
 Traction effort of wheel (wheel half worn 1015mm):
 Max. starting effort 392kN (40tf)
 Continuous effort 247,5kN (25,2tf)
 Number of driver cab 2
 Dimensions of locomotive layout
 Locomotive length over the buffer head \leq 20000 mm
 Max. width 3100mm (according to NEFA 604)
 Overall height (according to NEFA 604)

1.3 Diesel Engine

Designation: MTU16V4000R43 (Germany original).
 Model Four stroke, direct injection, exhaust turbocharged, air intercooled.
 Rated power under UIC condition 2200 kW
 Cylinder number and arrangement 16 cylinder Vee arranged
 Cylinder bore 170 mm
 Piston stroke 210 mm
 Rated speed 1800 r/min
 Idle speed 600 r/min
 Starting Motor driven
 Control mode: Electronic governor (Control voltage is 74V)
 Specific fuel consumption at rated power(SFC) 206+5%g/kW·h
 Specific oil consumption at rated power 0.5% of SFC (after 100 hrs operation)
 Engine mass with standard equipment:
 -Dry(without water and lube oil) Approx. 8360 kg
 -Wet(with water and lube oil) Approx. 8770 kg

1.4 Electric System

1.4.1 Main Alternator

Type: similar to model JF219C
 Rated power 2200kVA
 Rated voltage 321/620V(AC)



0088



Rated current 3955/2048A (AC)
Rated speed 1800r/min
Rated frequency 150 Hz
Traction coils 3-phase AC
Insulation class for exciter F/F
Excitation style Brushless excitation
Working system Continuous
Cooling style Radial self- ventilation

1.4.2 Rectifier unit

Type: similar to model GTF- 5100 /1250
Rated DC output voltage 1250 V
Rated DC output current 5070 A
Rectifier circuit: three-phase bridge type

1.4.3 Traction Motor

Type: similar to model ZD109B2X1
Rated power 530kW
Rated current 845/575A (DC)
Max current 1200A
Rated voltage 670/980V (DC)
Rated speed 770r/min
Max. speed 2385r/min
Excitation mode Series excitation
Working system Continuous
Cooling mode Forced ventilation

1.4.4 Auxiliary Generator

Type: similar to model ZQF-80
Rated power 80kW
Rated voltage 110V
Rated current 728A
Rated speed 1115/2730 r/min
Excitation mode
 Generation condition Separate excitation
 Motoring condition Series excitation
Working duty Continuous
Cooling mode Self ventilation

1.4.5 Dynamic Brake

Max. braking power $\geq 1800\text{kW}$
Allowable continuous current of resistor grid $\leq 525\text{A}$
Temperature of resistor grid $\leq 600^\circ\text{C}$



0088



1.4.6 Cooling Equipment

The cooling equipment of locomotive can meet radiating requirement of power equipment at operating condition. The cooling water system includes pipes, expansion water tank, pipes and rubber joint, etc. There is pressure regulate valve on water tank. Float ball type low level water alarm is installed in the water tank. There are also overflow water pipe and compensating water pipe. There are filling and draining water pipes in the system.

Radiator: Flat tube reinforce radiator

Radiator fan specified: Driven by hydrostatic motor. **(Requested Radiator fan type: Axial flow fan, driven by asynchronous varying frequency AC motor).**

1.4.7 Traction Motor Blower

Type Centrifugal

Rotating speed 2600r/min

Air flow 330 m³/min

Air pressure 4000Pa

Driving type specified: driven by elastic pin coupling sleeve from gear box. **(Traction motor blower requested: Centrifugal, driven by AC motor).**

1.4.8 Battery units

Type Ni-Cd GNC170

Rated capacity 220 Ah

Total voltage 96 V

1.5 Brake System

1.5.1 Type of air brake Knorr-Bremse CCBII, CCB 26 (Air brake)

1.5.2 Air compressor

Type KNORR-BREMSE SL22-72

Qty 2

Rated speed: 2600 r/min

Rated delivery pressure: 1000 kPa

Rated delivery capacity: 2400 L/min

Transmission mode specified: Driven by CC motor. **(Transmission mode requested: Driven by AC motor).**

1.5.3 Air Reservoirs

Quantity 2

Capacity 600 L

Max. pressure 1200 kPa

1.5.4 Air Dryer

Type: similar to model JKGEC

Quantity 1

Capacity 5 m³/min



0088



Relative humidity \leq 35 %
Pressure 500 ~1000 kPa
Drain manner Automatic

1.6 Bogie

Quantity 2
Axle arrangement Co-Co
Wheel base 1800mm
Wheel monobloc wheel according to UIC norms
Wheel diameter of new wheel 1050 mm

1.7 Carbody

Length between two buffer head end app. 20000 mm
Length over end plates 17600 mm
Width 3100 mm (according to NEFA 604)
Height of carbody 4280 mm (according to NEFA 604)
The height of the underframe above rail top 1600 mm
Coupler center height above rail top 1055 (-11, -35) mm
Height of the cowcatcher bottom above the rail top 150 +10 -0 mm

1.8 Interior Cab Facilities

1.8.1 Air-Conditioner

Type: similar to model JK5.0/DBP-03L.
Power supply 3 phases AC
380 V \pm 10%
50 Hz \pm 3%
Power input 5.0kW
Electricity supply 110 V DC
Quantity 2

1.8.2 Headlight

Quantity 1 of the front and the rear end each
Power 2X 800W
Power supply 110V DC

1.8.3 Mark Light

Model red and white
Quantity 4
Power supply 110 V DC

1.8.4 Hot plate

Power 1500W
Electricity supply 110 V DC
Capacity 1.7 L



0088



1.8.5 Speed Meter(equipped with speed recorder)

Speed range 0~200 km/h
Rated voltage 110 V DC
Power required app.20 W

1.8.6 Electric Heater(with fan)

Heaters on back wall 2X1800 W
Heaters for feet 2X750 W
Rated voltage 110V DC

NOTE 1: the original contract price matches the characteristics specified by the offerer. However, there are certain features that should be redefined in technical design meetings. These features may represent lower or higher cost. The higher costs arising from technical design meetings will be considered additional and those could be up to five percent of the originally price. Differences higher than five percent will be taken from the sum for turnouts, spare parts and tools. To claim higher costs, the supplier must technically justify and must have the approval of Belgrano Cargas y Logística S.A.

NOTE 2: Technical features of 1435mm gauge locomotives are the same as 1676mm gauge locomotives, except for those features to be adjusted according to the clearance details specified in NEFA 605.

NOTE 3: Technical features of 1000mm gauge locomotives are the same as 1676mm gauge locomotives, except for those features to be adjusted according to the clearance details specified in NEFA 606 and maxim axle load admitted. Traction motors will have similar benefits but with the limitations of geometry and maximum load permitted. These aspects will be considered and precisely defined in design meetings.

A handwritten mark resembling an 'X' or a signature, located in the bottom left corner of the page.

A handwritten mark resembling a signature or initials, located in the bottom right corner of the page.

0088

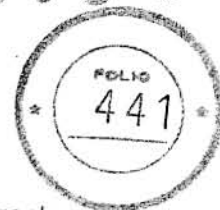

TECHNICAL SPECIFICATIONS FOR WAGONS

1. STANDARD

During design, material, manufacture, assembly and tests of the wagon, Contractor shall adopt the relevant railway standards. High-level quality control system shall be put into use in the project. The design, material, manufacture, assembly and tests of the wagon shall comply with Standard of the People's Republic of China except the air braking system which shall comply with the standard of Association of American Railroad (AAR).

2. COAL OPEN TOP WAGON (TRACK GAUGE:1676MM)

2.1 Application

Coal open top wagon is the railway freight car with end wall as well as side wall and has no roof. It is mainly used to transport coal, ore, building materials and other bulk goods.

2.2 Main performance parameters

| | |
|-------------------------------------|--|
| Gauge (mm) | 1676 |
| Number of axle | 4 |
| Max. axle load (t) | 25 |
| Carrying capacity (t) | ≥(no less than)77.5 |
| Tare weight (t) | ≤(no more than) 22.5 |
| Max. running speed (km/h) | 100 |
| Clearance | Meet the requirements of Argentina broad gauge railway clearance |
| Height of coupler center above rail | Meet the requirements of Argentina broad gauge railway |



0088

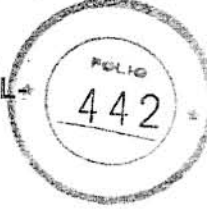

3. BALLAST HOPPER WAGON (1000MM, 1435MM, 1676MM, MANUAL OPERATED DISCHARGE)

3.1 Application

It is mainly used to transport stone ballast or ore.

3.2 Main performance parameter

| | |
|-------------------------------------|--|
| Track gauge (mm) | 1000 |
| Number of axle | 4 |
| Max. axle load (t) | 22 |
| Load capacity (t) | ≥(no less than) 67 |
| Tare weight (t) | ≤(no more than)21 |
| Max. operating speed (km/h) | 90 |
| Clearance | Meet the requirements of Argentina meter gauge railway clearance |
| Height of coupler center above rail | Meet the requirements of Argentina meter gauge railway |

| | |
|-------------------------------------|---|
| Track gauge (mm) | 1435 |
| Number of axle | 4 |
| Max. axle load (t) | 22 |
| Load capacity (t) | ≥(no less than) 66 |
| Tare weight (t) | ≤(no more than) 22 |
| Max. operating speed (km/h) | 100 |
| Clearance | Meet the requirements of Argentina standard gauge railway clearance |
| Height of coupler center above rail | Meet the requirements of Argentina standard gauge railway |

0088

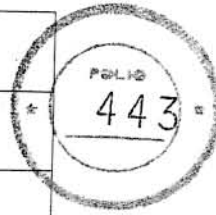

| | |
|-------------------------------------|--|
| Track gauge (mm) | 1676 |
| Number of axle | 4 |
| Max. axle load (t) | 25 |
| Load capacity (t) | ≥(no less than) 77 |
| Tare weight (t) | ≤(no more than)23 |
| Max. operating speed (km/h) | 100 |
| Clearance | Meet the requirements of Argentina broad gauge railway clearance |
| Height of coupler center above rail | Meet the requirements of Argentina broad gauge railway |

4. GRAIN HOPPER WAGON (1000MM, 1435MM,1676MM,MANUAL-OPERATED DISCHARGE)

4.1 Application

The car is basically applied to transport grain crops like soybean on track in Argentina.

4.2 Main performance parameter

| | |
|-------------------------------------|--|
| Track gauge (mm) | 1000 |
| Number of axle | 4 |
| Max. axle load (t) | 22 |
| Load capacity (t) | ≥(no less than)65 |
| Tare weight (t) | ≤(no more than)23 |
| Max. operating speed (km/h) | 90 |
| Clearance | Meet the requirements of Argentina meter gauge railway clearance |
| Height of coupler center above rail | Meet the requirements of Argentina meter gauge railway |

| | |
|------------------|------|
| Track gauge (mm) | 1435 |
|------------------|------|



0088

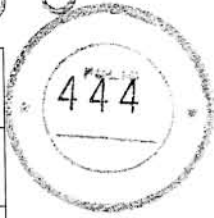

| | |
|-------------------------------------|---|
| Number of axle | 4 |
| Max. axle load (t) | 22 |
| Load capacity (t) | ≥(no less than)64 |
| Tare weight (t) | ≤(no more than)24 |
| Max. operating speed (km/h) | 100 |
| Clearance | Meet the requirements of Argentina standard gauge gauge railway clearance |
| Height of coupler center above rail | Meet the requirements of Argentina standard gauge railway |

| | |
|-------------------------------------|--|
| Track gauge (mm) | 1676 |
| Number of axle | 4 |
| Max. axle load (t) | 25 |
| Load capacity (t) | ≥(no less than)75 |
| Tare weight (t) | ≤(no more than)25 |
| Max. operating speed (km/h) | 100 |
| Clearance | Meet the requirements of Argentina broad gauge railway clearance |
| Height of coupler center above rail | Meet the requirements of Argentina broad gauge railway |

5. FLAT WAGON (1676MM)

5.1 Application

The flat wagon is basically applied to transport many kinds of goods, such as steels, cased goods, and machinery equipment on track in Argentina.

5.2 Main performance parameter

| | |
|------------------|------|
| Track gauge (mm) | 1676 |
|------------------|------|



0088

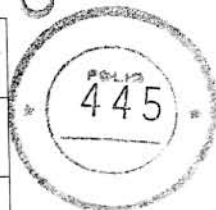

| | |
|-------------------------------------|--|
| Number of axle | 4 |
| Max. axle load (t) | 25 |
| Load capacity (t) | ≥(no less than)78 |
| Tare weight (t) | ≤(no more than)22 |
| Max. operating speed (km/h) | 100 |
| Clearance | Meet the requirements of Argentina broad gauge railway clearance |
| Height of coupler center above rail | Meet the requirements of Argentina broad gauge railway |

6. TECHNICAL DOCUMENTS

The technical documents of wagons shall be provided by Contractor to Principal. The details of the technical documents will be determined in the design liaison.

7. INSPECTION, TESTING, COMMISSION AND TAKING OVER

The inspection, testing, commission and taking over of wagons shall consist of two major phases as follows :

- (1) Inspection and testing of wagons at the Contractor's premises;
- (2) Commissioning and taking over of wagons at the Principal's premises.

7.1 Inspection and Testing of Wagons in the Contractor's premises

7.1.1

The pre-delivery inspection and testing shall be carried out by the Contractor in its premises in the presence of the Principal's authorized inspectors. And all results of such inspection and test shall be deemed to have been accepted by the Principal.

7.1.2

The Contractor will at its own expense provide all test equipment, facilities and any other necessities during the time of inspection and testing of wagons.

7.1.3

The inspection and testing to be carried out will include the following items:



0088

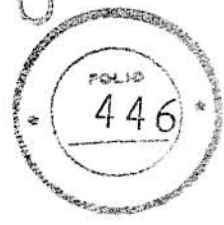

- (1) Test of Car body static strength (This test only applies to the 1st wagon of each kind.)
- (2) Test of dead weight (This test only applies to the 1st wagon of each kind.)
- (3) Test of static load (This test only applies to the 1st wagon of each kind.)
- (4) Clearance test (This test only applies to the 1st wagon of each kind.)
- (5) Brake, coupler performance and handbrake test
- (6) Hopper wagon bottom discharge test (This test only applies to the 1st wagon of each kind.)
- (7) Curve negotiation test (This test only applies to the 1st wagon of each kind.)
- (8) Dynamic calculation (This test only applies to the 1st wagon of each kind.)
- (9) Center of gravity calculation (This test only applies to the 1st wagon of each kind.)

7.2 Commissioning and Taking over of Wagon at the Principal's premises

7.2.1

When the wagons are delivered to the Principal's premises, the Principal will, as soon as possible but not later than two weeks thereafter, carry out commissioning and taking over of the wagons under the supervision and instruction of the Contractor's technical personnel. Both parties shall fully cooperate together. Wagons taking over period should not exceed one month.

7.2.2

During the course of commissioning and taking over of the wagons, the Principal shall be responsible for preparing and providing shunting movements, lifting and other necessary facilities, all other necessary consumables and labor at its own costs.

7.2.3

During the commissioning, the following verifications and tests shall be performed by both the Principal's Representatives and Contractor's Representatives:



0088



(1) Brake test on rail

The purpose of the test is to check the performance of wagon's brake effort. Generally speaking, test's validity greatly depends on the quality of the surface of the test rail and the climate, so there is something to be defined based on mutual negotiation.

(2) Synchronous Test (This test only apply to the 1st wagon of each kind.)

Inspect synchronous functions between wagon and locomotive.

The wagons shall be taken over by the Principal after completion of the above commissioning. On schedule maintenance and related consumables and easy-worn parts shall be borne by the Principal in guarantee period.



0088

TECHNICAL SPECIFICATIONS FOR WAGON PARTS

TECHNICAL SPECIFICATIONS OF THE AXLE

(1000mm, 1435mm, 1676mm)

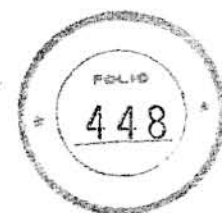

1. General requirements of 1000mm gauge axle
 - (1) Apply to Argentina cargo railway (gauge is 1000mm)
 - (2) In accordance with standards of AAR M-101/2012
 - (3) Plan: the drawings shall be confirmed by both sides.
2. General requirements of 1435mm gauge axle
 - (1) Apply to Argentina cargo railway (gauge is 1435mm)
 - (2) In accordance with standards of AAR M-101/2012
 - (3) Plan: the drawings shall be confirmed by both sides.
3. General requirements of 1676mm gauge axle
 - (1) Apply to Argentina cargo railway (gauge is 1676mm)
 - (2) In accordance with standard of AAR M-101/2012
 - (3) Plan: the drawings shall be confirmed by both sides.
4. Acceptance test

The following technical documents should be provided during the acceptance test:

 - (1) Dimension inspection records (each axle)
 - (2) Ultrasonic inspection records (each axle)
 - (3) Magnetic particle inspection records(each axle)
 - (4) Chemical composition inspection of the products

| C % | S % | Mn % | Si % | P % | V % |
|-----------|-----------|-----------|---------|----------|-----------|
| 0.45-0.59 | Max 0.050 | 0.70-1.00 | Min0.15 | Max0.045 | 0.02-0.08 |

- (5) Certificate of quality
5. About the product manufacturers
 - (1) The product manufacturer should have the AAR quality system certification
 - (2) There should be a person responsible for the ultrasonic examination and magnetic particle inspection, and this person should have the qualification



0088

"SNT-TC-1A, level 2 certificate" (The association of American Railroads nondestructive testing personnel qualification certificate, level 2).



6. Product Marking

The marking should completely follow the AAR print standard.

Permanent markings marked on the axle shall include the following information

- (1) Name of the manufacturer
- (2) Date of manufacture
- (3) Identification number

The typeface and font size of the marking should fulfill the AAR standard.

7. Packing and Transportation

When delivery, the products should be packed and protected in accordance with the following requirements

(1) External protection

- a) Anti-rust protection: the shaft end of axle shall be coated with oil, pasted with oil paper and sheathed in protective sleeve, and the other parts shall be pasted with anti-rust oil.
- b) The place where wheel seat, shaft contacted the packing rack should be covered by rubber.

(2) Packing and handling

Whole case packaging and the products shall be fixed and steady in the package. Handling supported goods shall meet the requirements of parking and storage to ensure that it can bear under the condition of stationary state and without deformation force.



0088

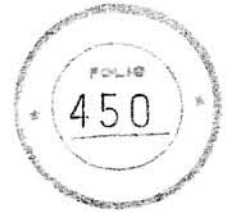

TECHNICAL SPECIFICATION OF WHEEL FOR WAGON

GAUGE 1000mm, 1435mm, 1676mm

ATC. L01.T1.002 (E2)

1. Contents

Description

- a) Semi-finished solid wheel for light and heavy wagons (gauge 1000mm)
- b) Semi-finished solid wheel for light and heavy wagons (gauge 1435mm , 1676mm)

Application: mechanical part—double-axle bogie

- a) 1000mm gauge wagons
- b) 1435mm or 1676mm gauge wagons

Safety level: level A (safety material-safety level: 100)

2. **Technical Documents:** The following technical documents are related to the general characteristics and process of manufacture and testing.

Plans

- a) NEFA 1263/3 –ÍTEM b)
- b) NEFA 1262/6 –ÍTEM b)
- NEFA491
- NEFA 275

Special standards (optional)

- AAR M107-208-class (B)

General standards

- NDT test personnel eligibility criteria
- Reference standards

0088

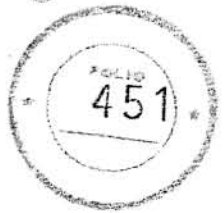

3. Testing

Testing shall be done in accordance with relative technical documents. The following technical documents shall be provided for testing:

AAR M107-208

- 1) Chemical composition description (13 elements)
- 2) Dimension inspection report (each wheel)
- 3) Ultrasonic inspection records (each wheel)
- 4) Magnetic inspection records (each wheel-random)
- 5) Brinell hardness reports
- 6) Determination report of heat treatment gradient

4. Particular Notes

- The supplier shall conform to AAR quality assurance program certification. The supplier shall also provide supporting documents to prove that the certification is within the valid period. The control and testing records provided by the foresaid supplier shall be the original version with signature of its responsible person. The documents shall be presented along with delivery of the corresponding batch of products.
- There shall be a qualified person with a valid certification in charge of the non-destructive testing.

5. Marking

In accordance with the plan NEFA491, the following information shall be marked on the products

- Symbol of the manufacturer
- Order or contract number
- Month and year of manufacture (month/year)
- Serial number
- Batch number
- Class or type



0088

6. Packing and Transportation

Before delivery, the products should be packed and protected in accordance with the following instructions.

- Exterior protection
 - (1) Anti-rust protection
 - (2) Protected by plastic exterior
- Packing and handling
 - Use transportation shelves and stack every 4 wheels.



00800
 453

TOLERANCIAS DE LABRADO Y SIMBOLOS DE LABRADO NO ESPECIFICADOS IRAM 4517

TOLERANCIAS DE FORMA GEOMETRICA IRAM 4515

ES COPIA DEL PLANO NEFA 1263
 M. BELLOMORO - GERENTE DE ORDENAMIENTO - C.N.R.F.

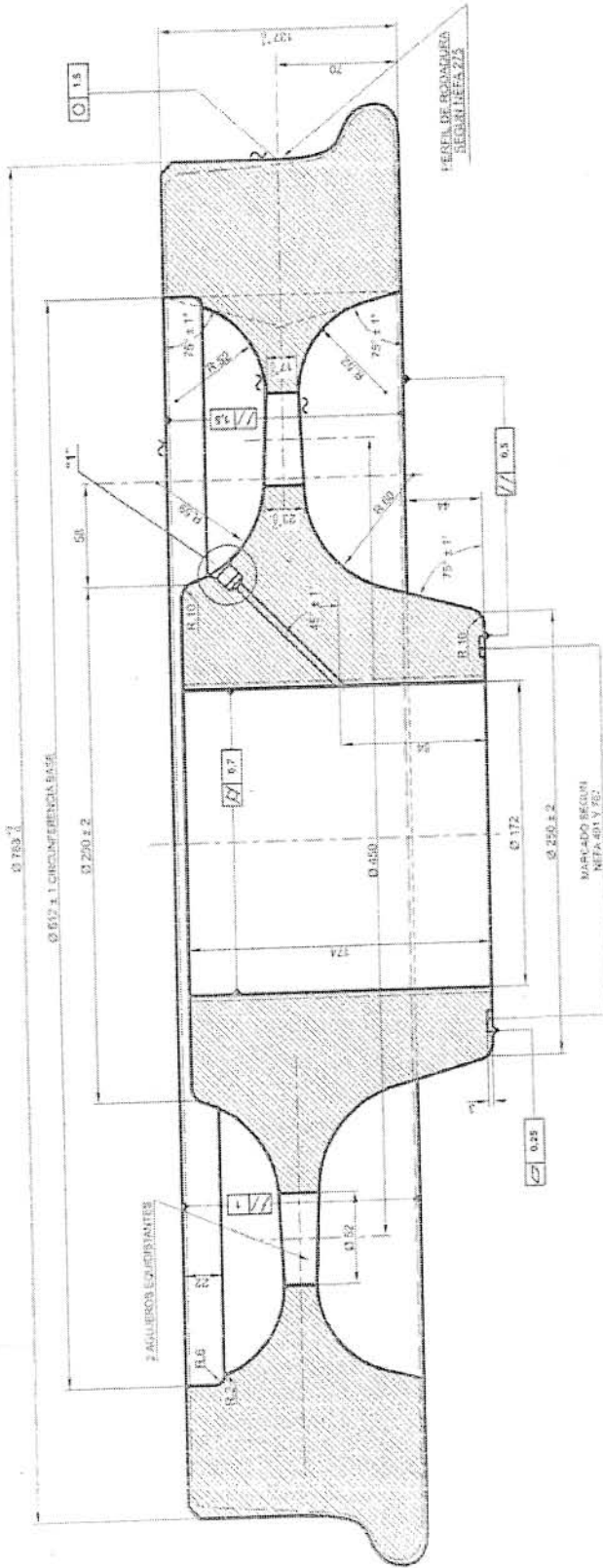

PARA RUEDA TERMINADA VER NEFA 1242

NOTA:
 EL CALADO SE AJUSTARA A LA ESPECIFICACION FAT: MR-500
 GEOMETRIA DEL PAR MONTADO SEGUN FAT: MR-704

EL ASPECTO SUPERFICIAL DEBERA APARECER LIBRE DE REPLIEGUES, FISURAS, INCLUSIONES, GRIETAS, FALTA DE MATERIAL Y TODO OTRO DEFECTO QUE AFECTE LA UTILIZACION DE LAS RUEDAS.

* SE INDICARA EXPRESAMENTE

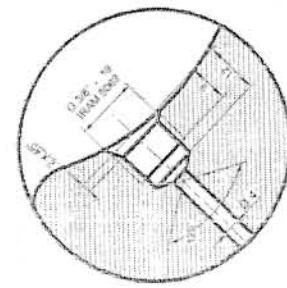

| | | | | |
|------|-----------------------------|----------|--|-------------|
| ITEM | DESCRIPCION | CANTIDAD | ESPECIFICACIONES Y OBSERVACIONES | CATALOGO |
| b | Rueda semiterminada vagones | | Especificación F.A. 8 005 - Tipo R.8 | 90517000000 |
| a | Rueda semiterminada cochis | | Especificación F.A. 8 005 - Tipo T.6 O.R.2 | 90517070000 |

| | | | |
|--|--------------------------------------|--|-----------|
| FEHERRIA ARGENTINOS | | AREA | MECANICA |
| RUEDAS ENTERIZAS LAMINADAS DE Ø 762 mm TIPO SEMIPESADA SEMITERMINADA | | | |
| ESCALA | 1:2.5 | TRUCHA | 1060 |
| LINKAS | BELGRANO | UTILIZACION MATERIAL REMOLCADO EJE 5" X 3" | NEFA 1263 |
| PRIMA Y FECHA ATRIBUIR | Ing. Enrique Prieto Gerente Mecanica | Nº DE PLANO | |
| EMISION | | | 3 |

| | | | |
|---------|--|--------------|---------------|
| 3 | SE MODIFICÓ ZONA DE MARCADO SEGUN PLANO NEFA 401 | 25/201 | FECHA - FIRMA |
| 2 | SE LE ADEGOÓ POR PEDIDO NOTA GUBINECTIV 1843 DEL 04/06/86 AGUJERO PARA MANIPULEO | | |
| EMISION | COTA | ALTERACIONES | |

0088

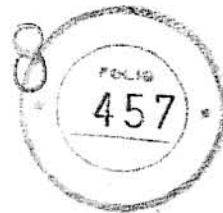

TECHNICAL SPECIFICATIONS FOR BEARING OF WAGONS

ATC. L01.T1.006 (E2)

1. Contents

Description

- a) Bearing 5 ½" X 10" (Class D).
- b) Bearing 5" X 9" (Class C).

Application: mechanical part-wheels

- a) Wagons with axle of 5 ½".
- b) Wagons with axle of 5".

Safety level: level A (safety material-safety level: 100)

- 2. **Technical Documents** —all the technical documents on general requirements manufacture and control under this Technical Specification.

Plan: NEFA 934 (for reference)

Design and make standards: AAR 934

General standards:

AAR Bearing specification (table1) or similar

Reference standards

3. Testing

Testing before delivery shall be made in accordance with relevant technical documents. The following document shall be provided before delivery:

- Unlimited conditional permit (awarded to certain brands by AAR)

4. Particular Notes

- 4.1. The bearing to be provided shall be in the brand which has the quality certification of AAR, such as SKF – TIMKEN – FAG – NSK – NTN – KOYO



0088



4.2. Equivalence, interchangeability and compatibility of its technical characteristics shall be ensured. (dimension, components, dynamic and static load, rotating speed)

5. Marking

Permanent markings made on the bearings shall include the following information:

- (1) Symbol of the Manufacturer
- (2) Brand
- (3) Month and year of manufacture (month/year)
- (4) Serial number

6. Packing and Transportation

Before delivery, the products shall be packed and protected in accordance with the following instructions.

6.1 Exterior Protection

Original package in the country of origin shall be used for the purpose of storage. (Cartons and nylon covers shall be used)

6.2 Packing and transportation

The products shall be packed in trays. The package shall ensure that the products are fixed and steady during transportation, and it won't move while any part of the products is handled.



008
 FOLIO
 459

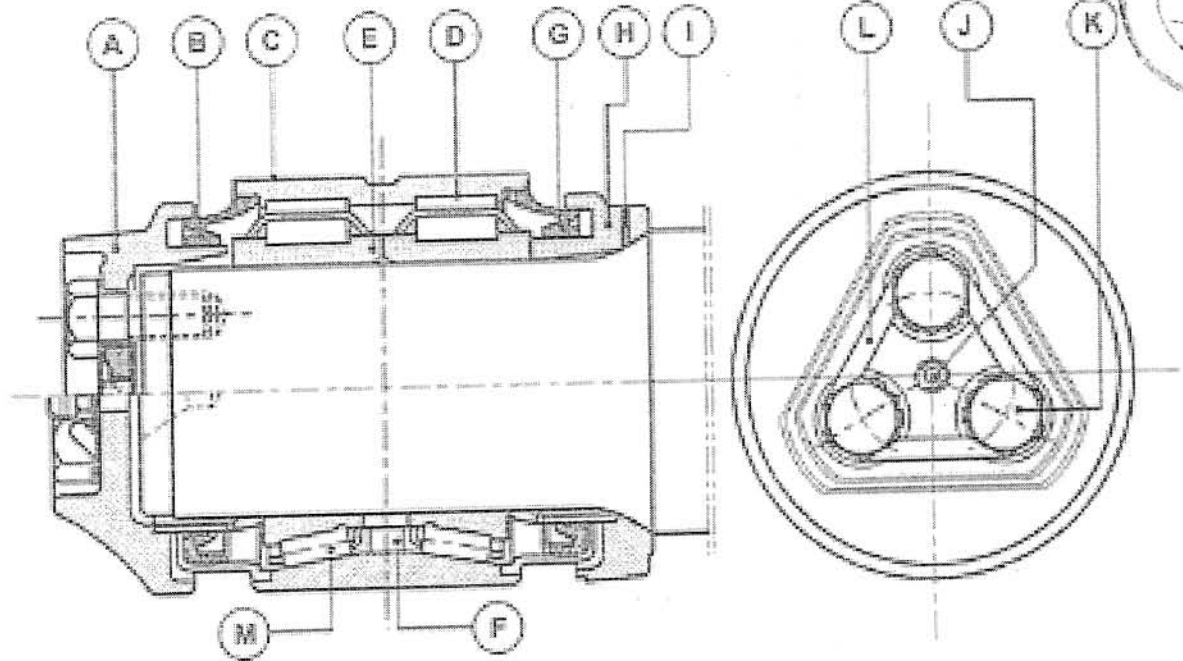

| | | | |
|---|---------------------|---|----------------------------|
| G | Retén interior | | |
| F | Anillo separador | M | Rodillo |
| E | Jaula de rodamiento | L | Placa de fijación |
| D | Pista interior | K | Bulones p/apa frontal |
| C | Pista exterior | J | Tapón obturador en engrase |
| B | Retén exterior | I | Grillado de drenaje |
| A | Tapá frontal | H | Collar de tope |

| ITEM | DESCRIPCION | CANT. | ESCUADRIA ESPECIF. Y OBSERVAC. | CATAL. NOMBEN |
|--|-------------|-------------|--------------------------------|--------------------------------|
| NOMENCLATURA DE PARTES DE LOS MANGUITOS A RODAMIENTOS | | | | FERRICARILES ARGENTINOS |
| | | | | AREA: MECANICA |
| ESCALA | TROCHA | LINEA | UTILIZACION | VERSION |
| | TODAS | TODAS | MATERIAL REMOLCADO | 1 |
| FIRMA Y FECHA ASESOR | | N° DE PLANO | | |
| | | NEFA 934 | | |

Table 1 AAR bearing specifications

0088

TECHNICAL SPECIFICATIONS FOR THE AIR BRAKING SYSTEM OF WAGONS

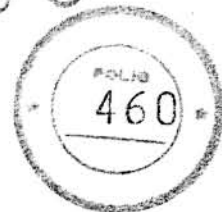

ATC. L01.T1.009 (E2)

1. Contents

Description: full set of air braking system (without tube)

Application: Mechanical part-braking system of wagons

Components:

- Control valve
- Pipe bracket
- Empty/load valve
- Service portion
- Dirt collector
- Combined auxiliary & emergency reservoir
- Accessories and coupling
- Automatic adjuster
- Cylinder 10 x12

Full set of KNORR-BREMSE, with control valve DB-60 (DB10 service portion/ DB30 Pipe bracket / DB20 Combined auxiliary & emergency reservoir)

Safety level: level A (safety material-safety level: 100)

2. Technical Documents—all the technical documents on general requirements, manufacture and control under this Technical Specification

Plan

- NEFA 563 (for reference)
- NEFA 968 (for reference)
- NEFA 969 item b) (for reference)
- Classic structure of the air braking system (model KNORR-BREMSE)

Special standards

- AAR S-400.



0088



- AAR S-401.
- AAR S.461-76
- AAR S.464-78
- AAR S.462-78
- Chapter E of Manual Standards and Recommended Practices -
AAR

General standards

- Reference standards

3. General Requirements

In any case, the requirements of AAR S-400 and AAR S-401 shall be fulfilled.
(Also refer to ALAF 1-030).

4. Supplier

As for the following three types of braking system suppliers: if the supplier

- Has the certification of AAR: Article 4.7 of ALAF 1-030 shall be satisfied
- Has the production permit of AAR: Article 4.6 of ALAF 1-030 shall be satisfied
- Doesn't have the certification of AAR, Article 4.5 of ALAF 1-030 shall be satisfied

5. Testing

Testing shall be conducted in accordance with relative technical documents. The following technical documents shall be provided for testing and acceptance:

- Limited or unlimited supply permit of AAR (control valve and accessories)
- Comply with detailed description of article 3.8.3.1 and 3.8.3.2 of AAR S.462-78
- Component list and operation manual of the control valve



6. Particular Notes

The supplier must comply with special standards of the braking system and have the certification of AAR or IRIS. The supplier shall also provide supporting documents to prove that the certification is within the valid period.

7. Marking

The delivered products shall have the following permanent markings:

- Symbol of the manufacturer
- Order or contract number
- Year and month of manufacture (month/year)
- Identification number of the components

8. Packing and Transportation

Packing and transportation of the products shall comply with the following instructions.

- Exterior protection

The products shall be protected by damp-proof plastic exterior (for control valves and cylinders).

- Packing and transportation

The complete set of equipment shall be packed in stackable wooden cases with lids.

9. Note:

The following drawings and pictures is just for reference, and the final drawings shall be defined in the design liaison.



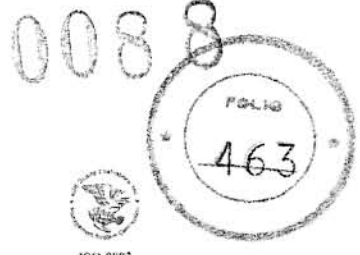

Structure and components of the air braking system



KNORR BREMSE
Sistemas Para Vehiculos Ferroviarios Ltda

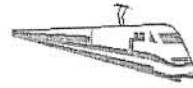

ISO 9002
Certificate Number 31804

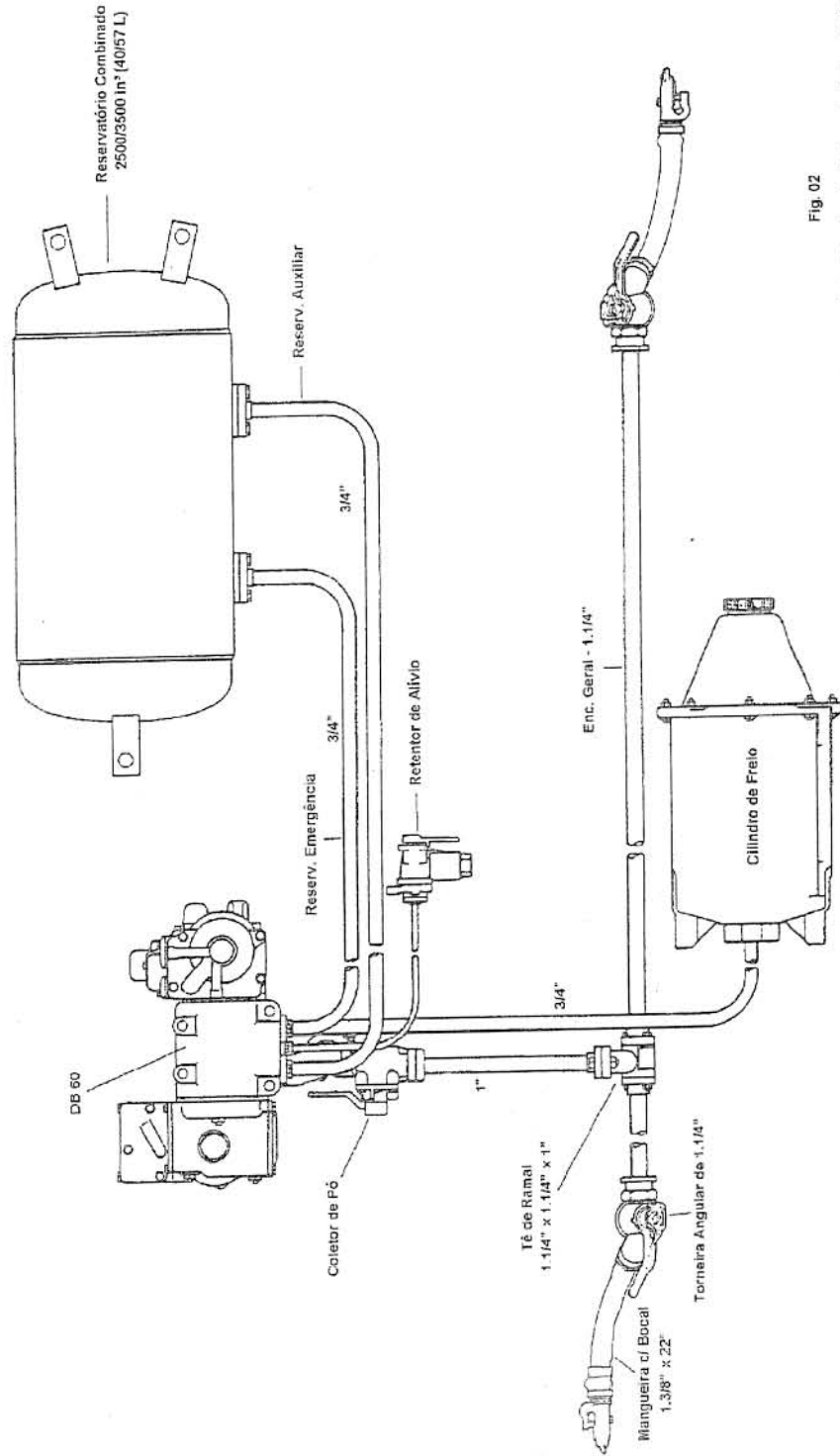

Fig. 02
Esquema das tubulações do Sistema de Freio - DB-60

008

FOLIO 465

ES COPIA DEL PLANO NEFA 958
1011 OCCISO - 4754, 502 METROS - C 1011

SE USARAN BULONES DE 20 TON POR
LARGO REDONDO CON ARABEOLA
CROMER, TUERCA CASTELANA Y PASADOR.

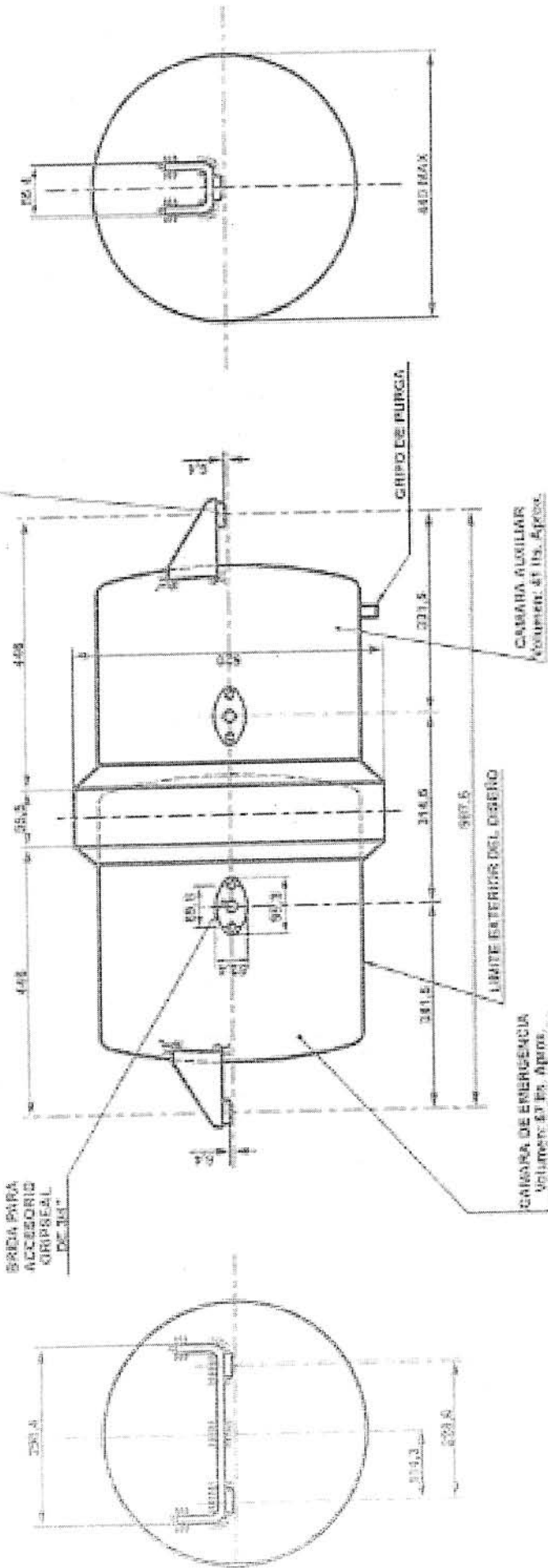

BRIDA PARA
ACCESORIO
GRIPSEAL
DE 158"

CAMARA DE EMERGENCIA
Volumen: 47.5 litros

LIMITE EXTERIOR DEL DISEÑO
987.5

CAMARA AUXILIAR
Volumen: 47.5 litros

CHIP DE PURGA
20"

CONSTRUCCION DE PRUBA: 16.2 kg/cm² - 230 PSI
CONSTRUCCION DE OPERACION: 8.1 kg/cm² - 115 PSI
LUBRICA UN REVESTIMIENTO INTERIOR DE PINTURA
EPON. EN LUBRICA SEGUIR NORMAS IMA 1111.
EN LA PARTE INFERIOR SE DEBERA PREVENIR LA
COLOCACION DE UN GRIFO DE PURGA.
QUE PUEDE CONTENER LOS CAMARAS

| | | | | |
|---|-------------|-------|---------------------------|------------|
| ITEM | DESCRIPCION | CANT. | PA. EDD144374EST SOLDABLE | CANTALONER |
| A | DEPOSITO | 1 | ESCAMERA SUPER. TUBERVAL | |
| EQUIPO ACCIONAMIENTO AUTOMATICO DE FRENO DEPOSITOS ASPECTOS CONDICIONADOS DEL DISEÑO | | | | |
| ESCALA | TRAZO | UNID. | UTILIZADA | ENTROR |
| | TODAS | TODAS | MATERIA. DEBENTE | |
| PLAN Y FORMA APORTE | | | | 2 |
| | | | | NEFA 958 |

| | |
|------------|------------|
| NO. PLANOS | NO. PLANOS |
| NO. PLANOS | NO. PLANOS |
| NO. PLANOS | NO. PLANOS |

DE ACCESORIO CANTIDAD DE PLANOS

2

X

[Handwritten signature]

0088

ES COPIA DEL PLANO NEFA 989
 M. APLICACIONES - COPIAS NO CONTROLADAS - C. A. N. P. S.

POLIG

466

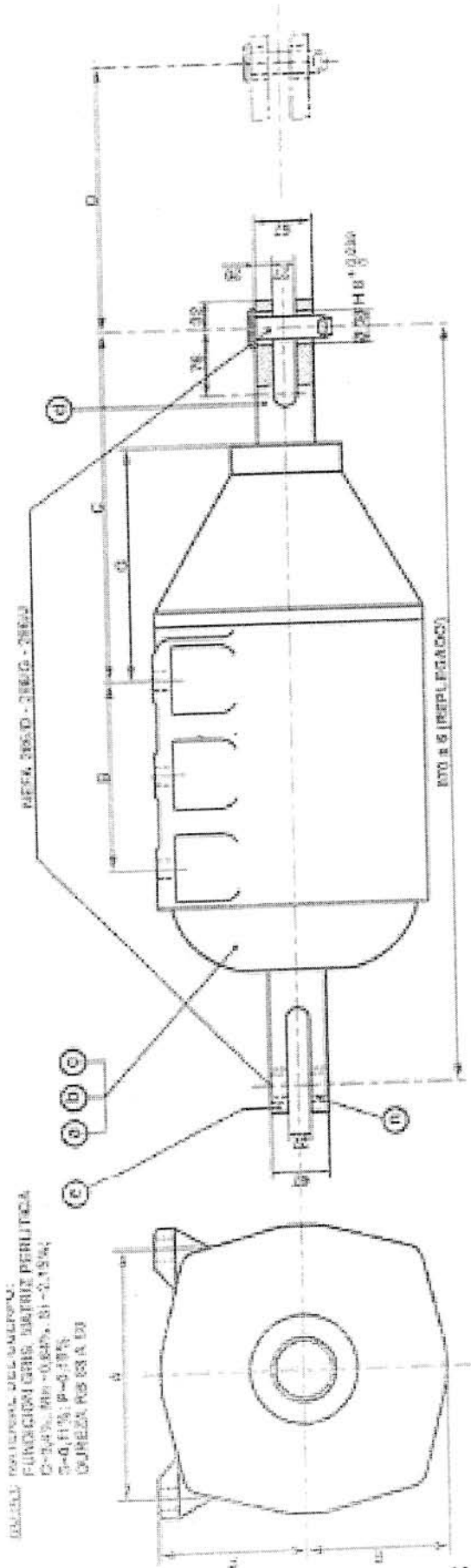

NOTA: EL MOVIMIENTO DEL EXTREMO DEL ENBILO SERA APTO PARA ACCOMPANAR EL DESPLAZAMIENTO DE SU CONEXION CON LA PALANCA VINA

NOTA: LOS ORIFICIOS DEL EXTREMO DEL VASTAGO Y COLA LLEVARAN CALZADOS BLUES SEGUN NEFA 818C

| | | | | |
|------|-------------------|-------|------------|-------|
| ITEM | DESCRIPCION | CANT. | REVISIONES | FECHA |
| 1 | BUJE | 2 | | |
| 2 | COLA | 1 | | |
| 3 | EXTREMO | 1 | | |
| 4 | CILINDRO COMPLETO | 1 | | |

FECHA: 10/04/78
 AREA: TOCLES
 TITULAR: TOCLES
 REVISIONES: 5
 DISEÑADOR: TOCLES
 DIBUJANTE: TOCLES
 VERIFICADOR: TOCLES
 APROBADO: TOCLES
 EMPRESA: MECANICA

| ITEM | DESCRIPCION | A | B | C | D | E | F | G | OBSERVACIONES |
|------|-------------|-----|-----|-----|-----|-------|-----|-------|---------------|
| 1 | 0.8 x 10 | 200 | 216 | 500 | 254 | 317.5 | 319 | | |
| 2 | 10 x 12 | 230 | 210 | 400 | 305 | 400 | 335 | 200.7 | |
| 3 | 12 x 18 | 300 | 270 | | 254 | 370 | 370 | | |

1. Según Nota 1. Según Nota 202 del C.A.N.P.S. del 10/04/78
 2. Según NEFA 989 - Nota 1 y 2
 3. Material "P" en 145. Material en 100
 4. Según 215, se construye 218 x 20. Material "S", en 100. Material en 100 y 20.
 5. Según 215 y 218 se construye 102 y 20.

[Handwritten signature]

0088
POLICIA
467

2.1 LOS REQUISITOS DE LA DB 60

La Válvula de Control DB-60 (fig. 1) es el componente principal del Equipo de Freno para vagones y coches de pasajeros remolcados por locomotoras. La Válvula de Control DB-60 posee aprobación de la AAR y rellena todos los requisitos establecidos en el Manual de Padrones de Prácticas Recomendadas de la AAR ("Manual of Standards and Recommended Practices").

La Compañía Vale do Río Doce (CVRD) del Norte utiliza las válvulas DB-60 en los coches de pasajeros remolcados por locomotoras.

DB 20
Porción de Emergencia

DB 10
Porción de Servicio

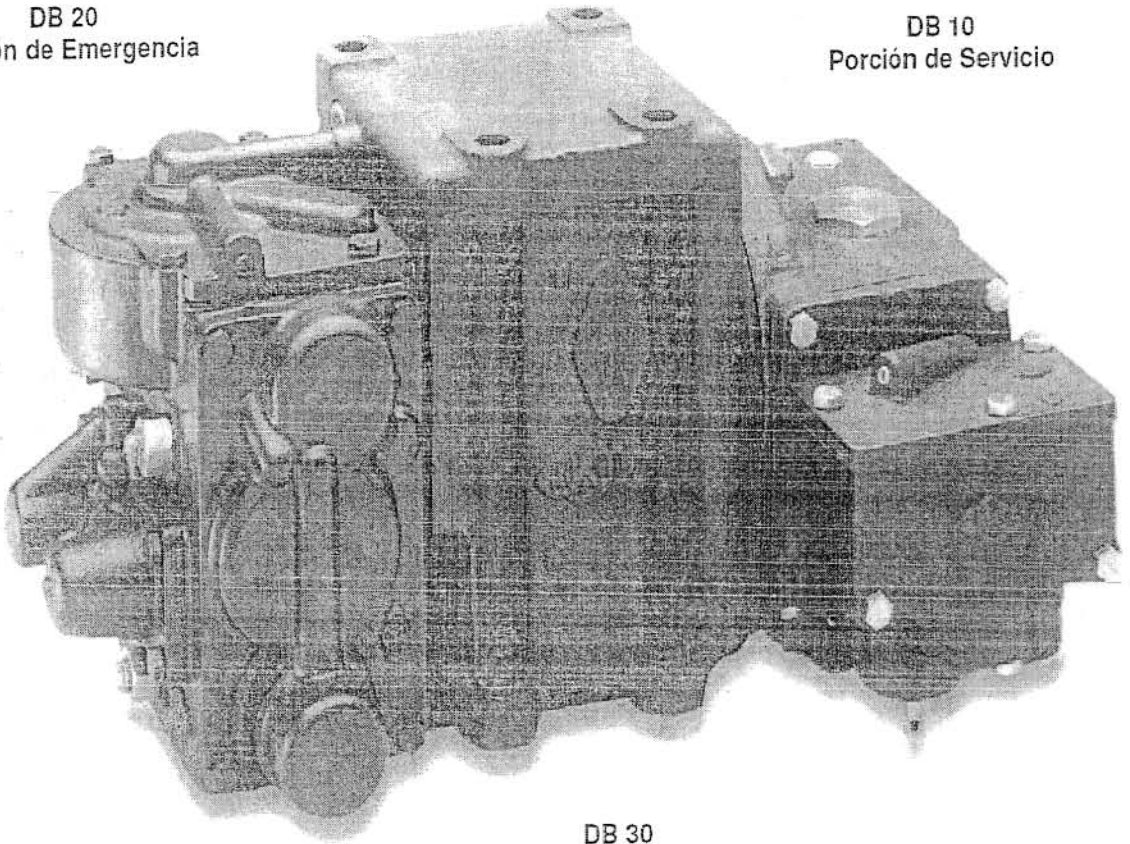

DB 30
Soporte de Tubería

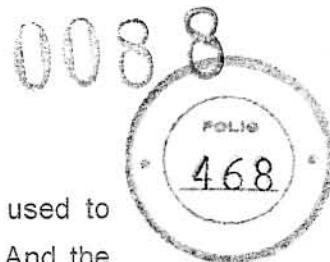

TECHNICAL SPECIFICATION –WAGON COUPLER

General description

Wagon coupler is mainly composed of coupler and draft gear. Coupler is used to connect and disconnect the wagon and transmit traction and impact force. And the draft gear is used to alleviate the traction and impact force. Wagon Coupler devices are adapted to normal railway wagon, meet the demands of the Chinese standard, can be normally connected to the coupler under the AAR standard, and meet the operation of Argentina railway.

Main components: 13B type coupler, MT-2 type draft gear, follower and coupler yoke key . A complete set of coupler is for one wagon.

13B Type Coupler

13B type coupler is mainly composed of coupler, coupler knuckle, coupler knuckle steel, coupler knuckle pin. 13B type coupler has the following characteristics:

- 1) The coupler body, coupler knuckle and coupler lock should be made of steel of Grade E meeting the requirements of AARM201. The maximum permanent deformation of the coupler knuckle will be less than 0.8mm under 1780kN, and its minimum destructive load is 3430kN, 18.7% higher than the AAR norm; the maximum permanent deformation of the coupler body will be less than 0.8mm under 3115kN, and its minimum destructive load is 4005kN.
- 2) The coupler knuckle has a contour with small clearance, which allows the coupler to make a longitudinal movement of 11.5mm, 41% less than the 19.5mm of the E type coupler, effectively reducing the longitudinal movement of the train and improving its security.
- 3) 13B type coupler can be used with the wagon couplers of type E and EF which conform to the contour of AAR S106 10A and that of type F which conform to the contour of AAR S117 F, provided with fair average quality of connection.

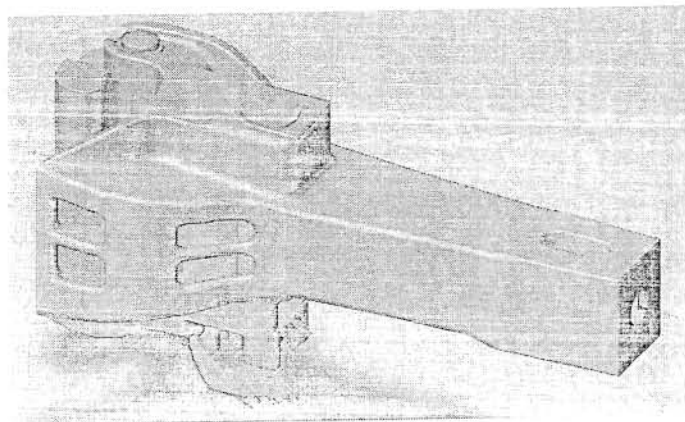

0038



13B type coupler 3D diagram

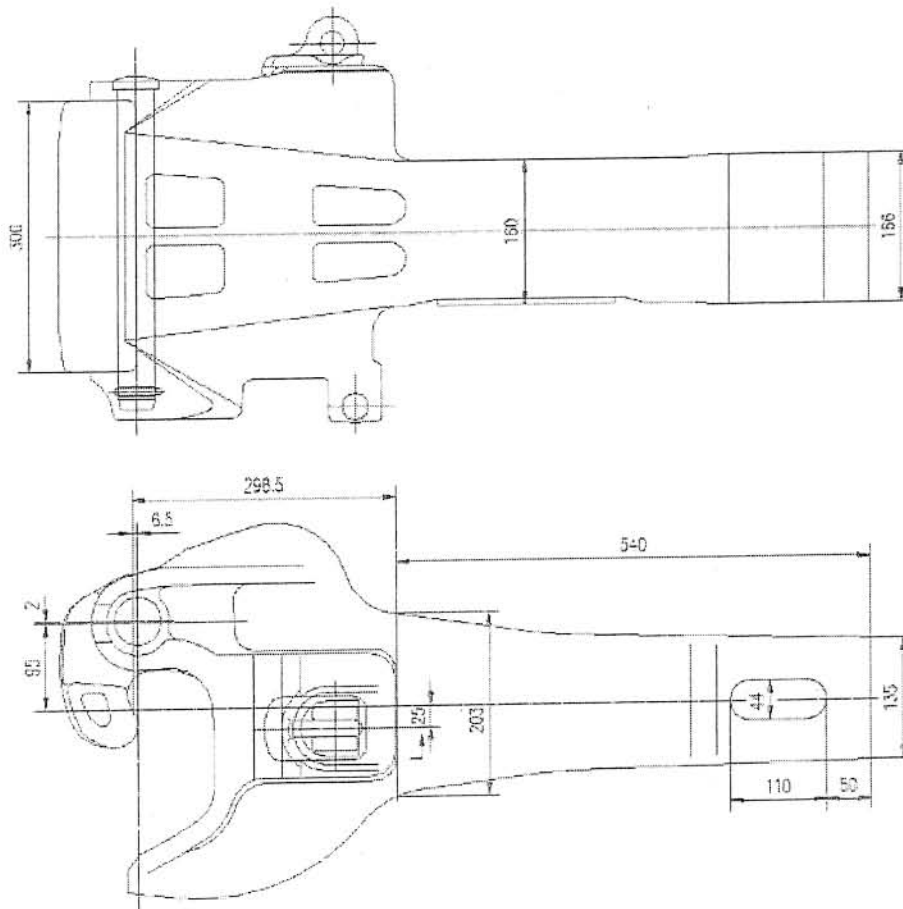

MT-2 Type Draft Gear

MT-2 type draft gear has the following characteristics:

- 1) Compliance with AAR M901E standards and mainly used on wagons with draft pocket dimension being 625mm between front and rear draft lugs.
- 2) The draft gear will be of the all steel spring type, mainly composed of housing, friction system and springs.
- 3) Draft gear will be delivered in pre-compressed status for easy operation
- 4) Main performance of MT-2 type draft gear:



0088

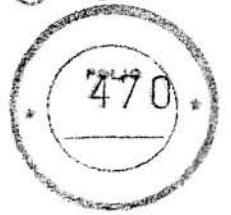

| Main performance | | |
|------------------|--------------|----------------|
| 1 | impedance | ≤ 2270 kN |
| 2 | capacity | ≥ 50 kJ |
| 3 | route | 83 mm |
| 4 | absorptivity | $\geq 80\%$ |

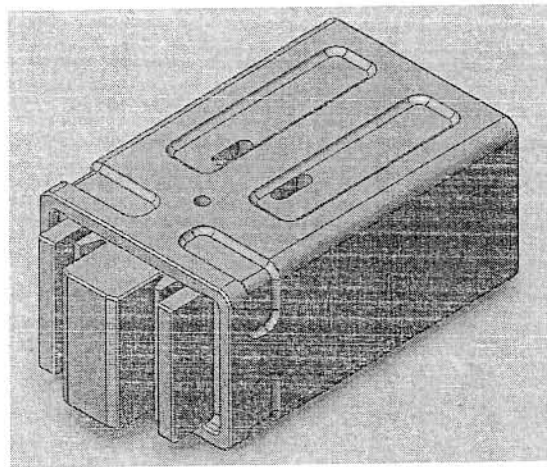

MT-2 draft gear 3D diagram

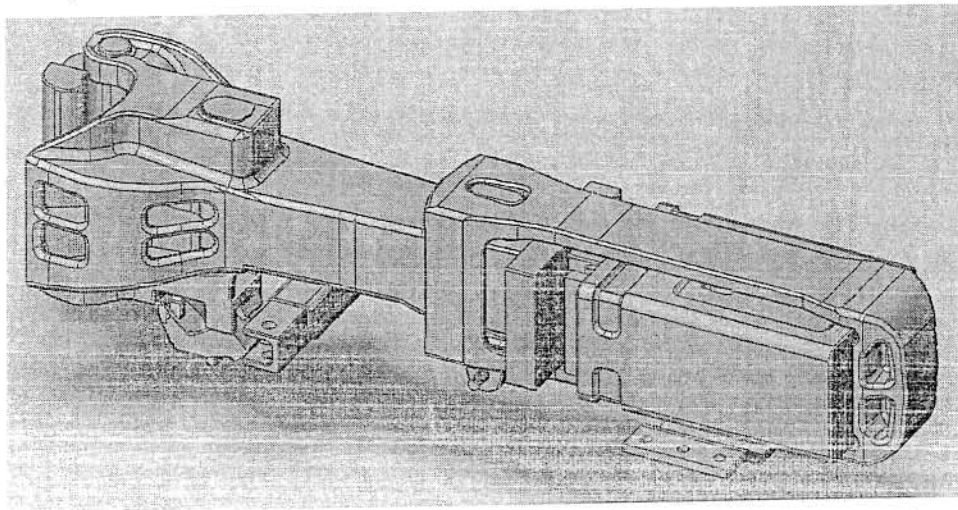

General 3D diagram

0088

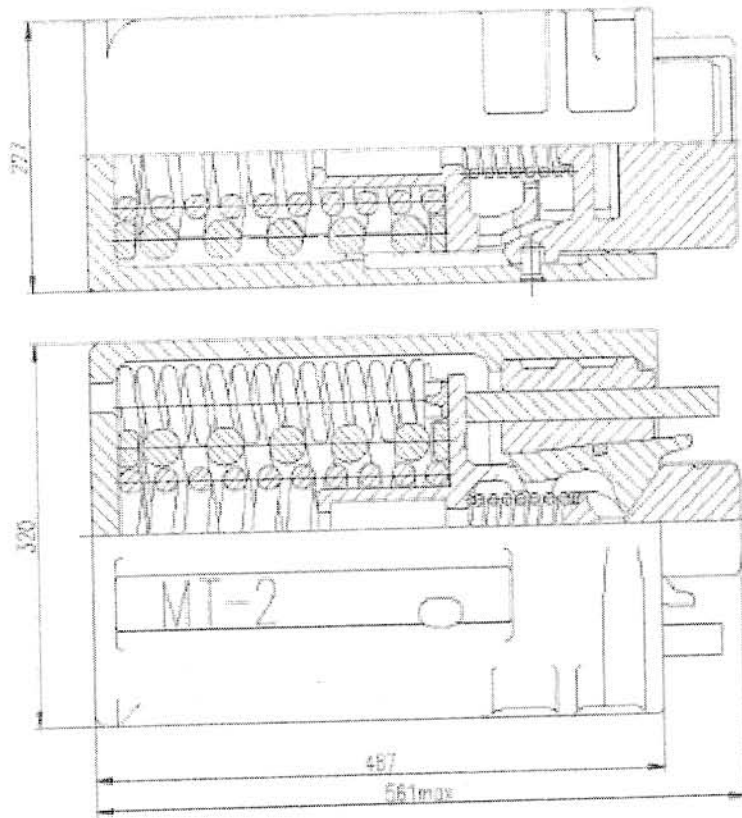

0088



ANNEX 2.3. TECHNICAL SPECIFICATIONS OF THE HEAVY MACHINERY

329DL Hydraulic Excavator

1. OVERVIEW

1.1 329DL Hydraulic Excavator is one of standard series of CATERPILLAR. The excavator adopts the most advanced and newest technique, provided with the high efficiency, high reliability, durability, and a better environmental protection.

2. TECHNICAL SPECIFICATIONS

2.1 Engine:

1. The CAT C7 engine adopts ACERT Technology developed by CATERPILLAR. The engine is six-cylinder, inline, water-cooled, diesel engine with ATAACC, turbocharger, HEUI (hydraulic electronic unit injector) and full-range electronic speed governor, providing sustained and stable output power, low speed and high torque and long service life. The quantity of the fuel injector can be adjusted automatically to the charge and the rotation rate with a faster response, a better fuel economy, a more complete combustion and a more environmentally friendly discharge.

- 2. Net flywheel power -----152kW
- 3. Rated speed -----1,800 rpm
- 4. Displacement -----7.2 L
- 5. Bore x Stroke -----110mm x 127mm
- 6. No power loss below an altitude of 2300 meters.
- 7. The discharge conforms to the European II Discharge Standard.

2.2 Hydraulic system

1. Main hydraulic system

- (1) Max. Pressure of system -----35000kPa
- (2) Main hydraulic pumps:



0088

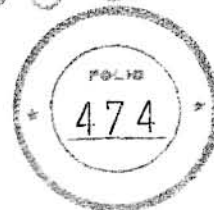

- Number -----2
- Flow -----2 x 235 L/min
- Type -----Axial piston pump

2. Pilot system

- (1) Max. Flow -----32.4 L/min
- (2) Max. Pressure-----3900 kPa

3. Hydraulic cylinder

- (1) Boom cylinder - Bore x Stroke -----140 x 1407mm
- (2) Stick cylinder - Bore x Stroke -----150 x 1646mm
- (3) Bucket cylinder - Bore x Stroke -----135 x 1156mm

4. Dual pump converging:

- The main system possesses two axial piston pumps. The dual pump converging utilizes effectively the engine power to improve the working speed.

5. Hydraulic cross sensing system:

- The hydraulic cross sensing system distributes reasonably the flow according to the operation to improve productivity with faster implement speeds and quicker, stronger pivot turns.

6. Hydraulic cylinder snubbers

- Cushion shocks, reduce sound levels, extend component life.

7. Boom and stick regeneration circuit

- Boom and stick regeneration circuit utilizes the fuel drain pressure of the cylinder and the dead weight pressure of the boom and stick to impress the return fuel to the cylinder, which increases equipment working speed, reduces working time and improves main pump efficiency.

8. Multiple functions:

- According to needs various devices can be equipped with.

2.3 Structures:

1. The X-shaped and the main frames adopt entire design and box-shaped structure. The stress is well-distributed during the process of the design, which makes the structure very firm provided with excellent resistance to torsion



0088

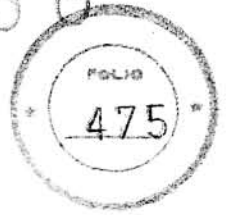

bending.

2. Enhanced boom, stick and bucket:

- Boom and stick adopt box-shaped welding structure provided with good resistance to torsion bending. Key weld seams have all passed the flaw detection.

2.4 Operator station environment

1. Operator station with internal pressurization

- Prevent effectively the invasion of noise and dust. Provide comfortable environment for the operator. Reduce weariness.

2. Air conditioner with automatic climate control

- Circulate and filter air.

3. Hydraulic activation control, appropriate position of lever.

- Convenient and quick.

4. Optional automatic operating mode:

- During the operation, the machine can choose automatically the appropriate mode according to the action and procedure of the lever without operator, improving greatly efficiency and reducing labor intensity.

5. Air suspension seat, four-way adjustments.

Above structures are all designed by CATERPILLAR.

2.5 Tree-levels warning function:

1. Class I: One lamp blinks
2. Class II: Two lamps blink
3. Class III: Two lamp blinks, buzzer warn.

2.6 High contrast monitor in Chinese, including information:

1. Quantity of fuel
2. Engine cooling liquid temperature
3. Fuel temperature
4. Error information
5. Fuel and filter maintenance cycle and engine, hydraulic pump and travel motor operating hours, etc.
6. Clock



0088



7. Engine speed and main system pressure.

2.7 Troubleshooting:

1. ET diagnostic Interface:

- Include automatic detection function, making the maintenance and troubleshooting quick, exact and convenient, reducing rest time.

2. Hydraulic system equipped with quick connector: CAT detection instrument can detect quickly and exactly hydraulic system errors and extract samples of hydraulic system and engine fuel.

2.8 Sealed and lubricated track: Track pin and pin bush adopt CAT unique grease lubrication seal

1. Prevent dust from invading into the connecting area, reduce wear and tear to the lowest level.

2. Reduce operating noise.

Above system components are all designed by CATERPILLAR.

3 SPECIFICATIONS AND PARAMETERS

| | | |
|------|---------------------------------------|---------------------|
| 3.1 | Operating Weight (kg) | 29,240 kg |
| 3.2 | Capacity of Bucket (m ³) | 1.54 m ³ |
| 3.3 | Flywheel Power (kW) | 152 kW |
| 3.4 | Maximum Travel Speed (km/h) | 5.3 km/h |
| 3.5 | Swing Speed (rpm) | 10.2 rpm |
| 3.6 | Swing Torque (kN·m) | 82.2 kN·m |
| 3.7 | Maximum traction (kN) | 249 kN |
| 3.8 | width of Shoes (mm) | 600 mm |
| 3.9 | Length of Boom (m) | 6.15 m |
| 3.10 | Length of Stick (m) | 3.2 m |
| 3.11 | Maximum reach at the ground level (m) | 10.6 m |
| 3.12 | Maximum digging depth (m) | 7.17m |
| 3.13 | Minimum loading height (m) | 2.37 m |
| 3.14 | Maximum loading height (m) | 7.02 m |



0088



| | | |
|------|--|-----------------------|
| 3.15 | Maximum vertical wall digging depth (m) | 6.51 m |
| 3.16 | Maximum cutting height (m) | 9.99 m |
| 3.17 | Maximum bucket digging force (kN) | 188 kN |
| 3.18 | Maximum Stick digging force (kN) | 128kN |
| 3.19 | Tail swing radius (m) | 3.08 m |
| 3.20 | Length of track on ground (m) | 3.99 m |
| 3.21 | Minimum ground clearance (m) | 490 mm |
| 3.22 | Gauge (m) | 2.59 m |
| 3.23 | Track Tensioning Type | Hydraulic tension |
| 3.24 | Pump type | Variable piston pump |
| 3.25 | Overall Transport dimensions (length X width X height) | 10.42 x 3.19 x 3.19 m |

329DL Hydraulic Backhoe Excavator Main Equipments List

329DL Hydraulic Excavator

1. Engine

The CAT C7 engine adopts ACERT Technology developed by CATERPILLAR and EFI, provided with higher fuel efficiency, and reaches European II Discharge Standard. The CAT C7 is equipped with efficient fuel-water separator and isolated cooling system.

Booster and air-cooled intercooler: Increase air getting into the cylinder, improve air inlet density, improve fuel combustion by reducing temperature and increase efficiency.

Cold start performance: Maintenance free large-capacity batteries, large-capacity starter motor and heavy-duty cables. Starting kit, cold weather, -32° C.

2. Hydraulic system

The equipment operating, swinging and walking adopt Pilot system.

Dual pump converging hydraulic system, boom and stick regeneration circuit

Automatic boom and swing priority function.

Hydraulic cylinder snubbers



0088

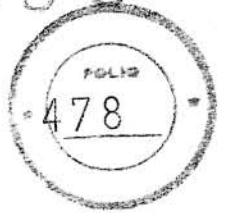

3. Operator station:

Operator station with internal pressurization, air conditioner with automatic climate control, air filter, suspension seat, full color liquid crystal display (LCD), alarm function.

4. Walking structure

- Double-speed, axial piston pump hydraulic motor
- Grease lubrication sealed tracks, thrust wheels, carrier wheels and guide wheels.

Tempered glass windows operator cab.

600 mm triple grouser track

Heavy-duty R6.15 m reach boom

Heavy-duty R3.2 m reach stick

Bucket linkage, CB-family

Cold weather starting kit

1.54m³ heavy-duty bucket linkage



0088



966H Wheel Loader Technical Specifications and Parameters

I. TECHNICAL SPECIFICATIONS

1.1 Power train

- (1) Engine: Caterpillar C11 engine with ACERT Technology –EPA Tier III, EU Stage III a Compliant
 - Model: C11 ACERT
 - Type: 6-cylinder, in line, water cooling, waste gate turbo charger, air-to-air after cooling (ATAAC), electronically controlled unit injection (MEUI) system
 - Net Power: 195kW (262hp) @1,800rpm
 - Displacement: 11.1L
 - Cooling system: Separated Cooling System, water tank and fan isolated from the engine, modular radiator, temperature-controlled speed adjustable fan
- (2) Transmission:
 - Type: electronically controlled, caterpillar planetary power shift transmission, electronic clutch pressure control
 - Transmission: 4 forward, 4 reverse
 - Maximum travel speeds: Forward 37.4km/h, Reverse 37.4km/h
- (3) Torque converter: Free wheel stator torque converter
- (4) Final drives: Automatic planetary power-shift transmission
- (5) Axles: Suspension semi-axle, heavy load, differential axle

1.2 Braking system

- (1) Service Brakes: Full hydraulic enclosed wet-disc free-adjustment 4-wheel brakes. The Integrated Braking System can lower the axle oil temperature and make the transmission smoother.
- (2) Parking Brakes: Spring brakes, Hydraulic brake release, Installed on the output axle of the transfer case, Dry-Disc brakes
- (3) Emergency Brakes: Adjustable and independent front and rear brake circuit, when the pressure of a loop drops, the other brake circuit can still work.

1.3 Hydraulic System

- (1) Type: Electro-hydraulic Implement Control with Load-Sensing Hydraulics



0088

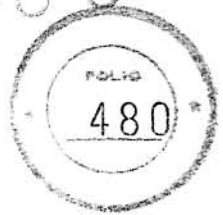

system&On-Demand Fan and Constant Net Powerimproving fuel efficiency.

- (2) Maximum flow: 305L/min
- (3) Safe relief pressure: 20,700kPa

1.4 Steering System

- (1) Load sensing steering system, articulated frame steering
- (2) Independent steering system

1.5 Structure (frame and arms)

- (1) frame and support tower: Box structure
- (2) lift arms: Double-arm structure

1.6 Cab

- (1) Pressurized and sound-suppressed closed cab. In Cab: Control system, monitoring system, instrumentation and switches.
- (2) Seat: all-way adjustable, suspension seat

1.7 Working device

- (1) Z-bar linkage
- (2) General Purpose Buckets: 4.0m³, bolt-on edge.

II. Parameters

- (1) Nominal load: 6.5t
- (2)Maximum bucket Capacity:4.25m³
- (3)Operating weight: 23,698kg
- (4) Engine
 - Net Power: 195kW
 - Peak Torque: 1,215Nm
 - Displacement: 11.1L
- (5) Maximum travel speeds:Forward37.4km/h
Reverse:37.4km/h
- (6) Hydraulic cycle:
 - Raise: 5.9s
 - Dump: 1.6s
 - Lower: 2.4s



0038

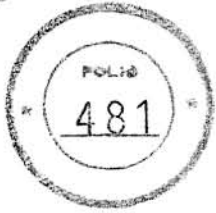

- (7) Axles:
 - Front: Fixed front
 - Rear: ±13°
- (8) Wheelbase: 3450mm
- (9) Wheel distance: 2230mm
- (10) Maximum dumping height
 - Forward dumping height (at full lift and 45° discharge): 3062mm
- (11) Dumping distance at full lift
 - Forward dumping distance (at full lift and 45° discharge): 1,434mm
- (12) Overall Height at Full Raise and 45° Discharge: 5859mm
- (13) Minimum steering radius (tire fringe): 6,590mm
- (14) BreakoutDepth: 121mm
- (15) Maximum breakout force: 186kN
- (16) Minimum distance to the floor: 496mm
- (17) Maximum turn (one side): 37°
- (18) Full Turn Static tipping load: 15,474kg
- (19) Noise in cab: 75dB(A)
- (20) Tires: 26.5R25
- (21) Dimensions: (L × W × H)..... 8682×3,220×3,600mm

Notes:

All the parts mentioned above, except the tires, are designed, produced and assembled by Caterpillar. The norms for design and production should be at least the domestic norm of Caterpillar 1E and the international ISO norm.

The tires should be triangle ones. Piece numbers are listed in the Manual.

The engine should be thoroughly repaired every 10000~12000 hours. Because of different working conditions and maintenance, every part of the 966H Wheel Loader has its own service life.

966H Wheel Loader Main Equipment



0088

966H Wheel Loader-Standard Equipment

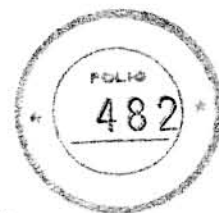

ELECTRICAL

Alarm (back-up), 115 A Brush alternator, electrical system (24-Volt), starter (heavy-duty),

Batteries (maintenance free), etc

OPERATOR ENVIRONMENT

Cab (ROPS/FOPS), air conditioner, defroster, seat, mirror (rearview), wipers

Electro-hydraulic lifting and tipping control, Lift and Dump position automatic adjustment,

Steering wheel

Monitoring system (EMS III)(including alarm system, instruments, alarm indicator)

POWER TRAIN

Integrated Braking System, full hydraulic enclosed wet-disc service brake;

Parking brake,

Cat C11 Engine with ACERT technology, Air-to Air Charge Air Cooler,

ADEM A4 control module

Next Generation Modular Radiator (NGMR), Temperature control fan

Air Filter

Wheel type torque converter (free wheel)

Automatic planetary power-shift transmission (3F/3R)

OTHER

Concentrated stress test interface, oil sampling valves, hydraulic oil cooler,



0088

automatic bucket positioner

Load sensing steering, hydraulic oil cooler, etc.

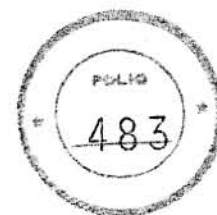

TIRES 26.5 R25 L3

DIRECTIONAL LIGHTS

LIGHT, DOME (CAB)

ROTATION CAUTION LIGHT

FRONT SUN VISOR

EXTERNAL MIRRORS

HYDRAULIC SYSTEM (THREE-VALVE)

FRONT AND REAR FENDERS, CHASSIS GUARDS

RRECLEANER (TURBINE)

HIGH TEMPERATURE COOLING SYSTEM

ENGINE COOLING LIQUID HEATER

4.0 m³ BUCKET

Note: As part of the whole, all of the materials above are included and installed on the machine, and none of them can be provided separately.



0088

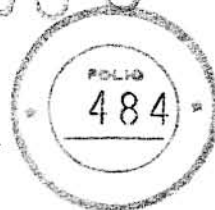

Specifications of M317D2 Wheel Hydraulic Excavator

1 OVERVIEW

- 1.1 M317D2 Wheel Hydraulic Excavator is one of the standard products of Caterpillar. This product uses the latest and newest technology, which brings more efficiency, high reliability/durability and a better environment protection.

2 SPECIFICATIONS

2.1 Engine:

The emission level of CAT C4.4 is equivalent to the emission standards of US EPA Tier III and EU IIIA. It has a higher performance and reliability, also lowers the fuel consumption and noise level. The engine has lower noise level of operator and observer, longer filter replacement cycle and higher fuel efficiency, also a better environment protection.

1. Flywheel power-----101kW
2. Rated rotator speed-----2,000 rpm
3. Displacement-----4.4L
4. Bore × Stroke-----105mm × 127 mm
5. No power loss under the altitude of 3000m
6. EU Stage IIIA STD
7. Maximum torque @ 1,400 rpm: -----550N·m

2.2 Hydraulic System

1. Main implement system

(1) Implement Circuit (heavy lift)-----37500 kPa

(2) Main Flow

Implement/Travel Circuit-----220 L/min

Auxiliary Circuit - High Pressure-----220 L/min

Auxiliary Circuit - Medium Pressure-----40 L/min

Swing Mechanism-----80 L/min

2.3 Transmission

Forward/Reverse

1st Gear 8 km/h

2nd Gear 34 km/h

Creeper Speed

1st Gear 3 km/h

2nd Gear 13 km/h

Drawbar Pull 97 kN



0088

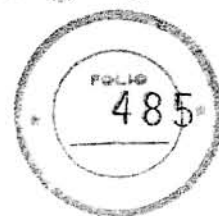

Maximum Gradeability 69%

- 2.4 Swing Mechanism
 - Swing Speed 10.5 rpm
 - Swing Torque 40 kN·m

3 DATA

- 3.1 Operating Weight 16,190 kg
- 3.2 Bucket 0.8 m³
- 3.3 Flywheel power 101 kW
- 3.4 Maximum Travel Speed 34 km/h
- 3.5 Swing Speed 10.5 rpm
- 3.6 Swing Torque 40kN·m
- 3.7 Drawbar Pull 97kN
- 3.8 Tail Swing Radius 2210mm
- 3.9 Overall Transport Dimensions (L× W × H) 8330×2550× 3150mm
- 3.10 Working Range:
 - 1 Digging Height----- 9070 mm
 - 2 Dump Height----- 6110 mm
 - 3 Digging Depth----- 5690 mm
 - 4 Vertical Wall Digging Depth----- 3650 mm
 - 5 Depth 2.5m Straight Clean-up-----5490 mm
 - 6 Reach-----9160 mm
 - 7 Reach at Ground Level-----8970 mm
 - 8 Bucket Forces (ISO 6015) -----101 kN
 - 9 Stick Forces (ISO 6015) -----74 kN

DUAL-Tire, 10.00-20 16 PRR

5.05m One-Piece Boom

2.4m Standard Sticks

0.8m³ General Purpose Bucket



0088

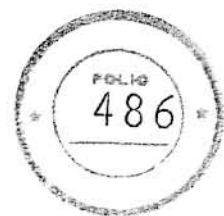

M317D2 STANDARD EQUIPMENT:

Electrical

- Alternator, 75A
- Lights
- Boom working light
- Cab interior light
- Rooding lights (front/rear)
- Working lights, cab mounted (front and rear)
- Main shut-off switch
- Heavy duty maintenance free batteries
- Signal/warning horn

Engine

- Automatic engine speed control
- Automatic starting aid
- Cat C4.4 engine with ACERT Technology Emits at levels equivalent to U.S.EPA Tire III and EU Stage IIIA emission standard.
- Fuel/water separator with level indicator

Hydraulics

- Heavy lift mode
- Load-sensing Plus hydraulic system
- Manual work modes (economy, power)
- Separate swing pump
- Stick regeneration circuit

Operator Station

- Adjustable armrests
- Air conditioner, heater and defroster with automatic climate control
- Ash tray with cigarette lighter (24 volt)
- Beverage cup/can and bottle holder
- Bolt-on FOGS capability
- Bottom mounted parallel wiping system
- Camera mounted on counterweight
- Coat hook
- Washable floor mat
- Fully adjustable suspension seat
- Instrument panel and gauges
- Information and warning messages



0088



- Gauges for fuel level, engine coolant and hydraulic oil temperature
- Filters/fluids change interval
- Indicators for headlights, turning signal, low fuel, engine dial setting
- Clock with 10-day backup battery
- Laminated front windshield
- Left side console, tiltable, with Locking mechanism for all controls
- Literature compartment behind seat
- Literature holder in right console
- Mobile phone holder
- Parking brake
- Positive filtered ventilation
- Power supply, 12V-7A
- Rear window, emergency exit
- Retractable seat belt
- Skylight
- Sliding door windows
- Steering column, tiltable
- Storage area suitable for a lunch box
- Sunshade for windshield and skylight
- Travel speed lock
- Visor for rain protection

UNDERCARRIAGE

- Heavy-duty axles, adjustable braking force
- Oscillating front axle with remote greasing
- Tires, 10.00-20 16 PR, dual
- Two tool boxes in undercarriage
- Two-piece drive shaft

OTHER EQUIPMENT

- Automatic swing brake
- Counterweight, 3500 kg
- Mirrors, frame and cab
- Product Link™ ready

All the system components above are designed and made by Caterpillar Inc..



0088

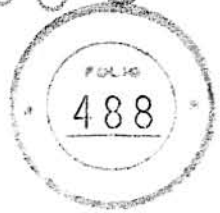

CS78B Vibratory Soil Compactor

SPECIFICATIONS AND PARAMETERS

Weights

Operating weights with cab: 18 700 kg

Power System

Engine model: Cat C4.4 ACERT

Gross power ISO 14396 - @2200 rpm: 129.5kW

ACERT provides the most advanced innovative technique for the extensively affirmed power system, controls accurately the combustion process and realizes more complete burning of fuel and lower discharge of tail gas. The engine confirms to the standards of tail gas discharge controlling of EPA Tier3 of USA and IIIa of Europe.

Speed - Maximum – 1.4km/h

Equipment Dimensions

Overall length – 6.13m

Overall width e – 2.46m

Height of the whole equipment - Maximum – 3.11m

Wheelbase – 2.90m

Ground clearance – 437mm

Turning radius inside drum edge - Minimum – 3.68m

Drum dimensions

Width – 2134mm

Thickness – 40mm

Diameter – 1534mm



0088

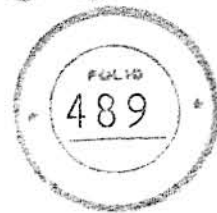

Vibratory system

Vibratory frequency – Maximum – 28Hz

Amplitude of the maximum vibratory frequency:

High – 2.1mm

Low – 0.98mm

Excitation force – Maximum – 332kN

Excitation force – Minimum – 166kN

The pod-style eccentric counterweight guarantees the extreme compaction function and the minimum amount of maintenance. Achieving the required density with the minimum rolling times shows the high-pressure strength. The needless of the scheduled oil sampling analysis for the vibratory system reduces the maintenance costs and increases the working time of the machine.

Other standard configuration

Electric system – 24V

Articulation angle – 34°

Pendulum angle – 15°

Notes:

In addition to the tires, all of the above components are designed, produced and assembled by CATERPILLAR. The CATERPILLAR 1E and the ISO international standards are adopted as norms for the production and the design.

Commissioning and acceptance will take place in Argentina with supervision of Caterpillar's local representative. All the starting up expenses shall be borne by CMEC.

0088

ANNEX 3 - SPARE PARTS

Spare parts list will be defined during Design Liason Meetings and shall be paid from the SUM FOR TURNOUTS, SPARE PARTS AND TOOLS listed in Annex-8 Total Contract Price Breakdown.

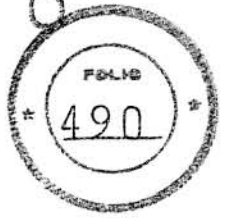

A handwritten signature in dark ink, appearing to be a stylized name.

A handwritten mark resembling a large 'X' or a stylized signature, located in the bottom left corner.

0088

ANNEX 4. LIST OF FREE OF CHARGE ATTENDANT TOOLS FOR THE
CONTRACT/LIST OF ACCESSORY TOOLS

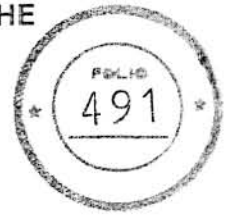

1. LOCOMOTIVE

The following list of free of charge attendant tools is for one locomotive (just for reference):

| Item No. | Description | Unit | Quantity |
|----------|--------------------------------------|-----------|----------|
| 1 | Inspection Hammer | pcs | 2 |
| 2 | Flat Chisel | pcs | 1 |
| 3 | Point Chisel | pcs | 1 |
| 4 | Hand Hammer (0.75kg) | pcs | 1 |
| 5 | Double dead spanner (6~24) | 8 pcs/set | 1 |
| 6 | Double dead spanner 27X30 | pcs | 1 |
| 7 | Single dead spanner 41,46,50,55,65 | pcs | 1 Each |
| 8 | Ring Spanner (6~27) | 6pcs/set | 1 |
| 9 | Adjustable spanner 200 | pcs | 1 |
| 10 | Adjustable spanner 300 | pcs | 1 |
| 11 | Socket spanner (10~32) | 28pcs/set | 1 |
| 12 | Screw driver 250 | pcs | 1 |
| 13 | Screw driver 100 | pcs | 1 |
| 14 | Screw driver 75 (Cross head) | pcs | 1 |
| 15 | Screw driver 50 | pcs | 1 |
| 16 | Pipe spanner 450 | pcs | 1 |
| 17 | Electrical Knife | pcs | 1 |
| 18 | Steel ruler 150 | pcs | 1 |
| 19 | Feeler gauge No.4 (14 pieces) | pcs | 1 |
| 20 | Feeler gauge No.2(16 pieces) | pcs | 1 |
| 21 | Signal lamp | pcs | |
| 22 | Oil kettle (2L) | pcs | 1 |
| 23 | Oil kettle (3L) | pcs | 1 |
| 24 | Oil barrel (10L) | pcs | 1 |
| 25 | Oil barrel with strainer (10L) | pcs | 1 |
| 26 | Detonator | pcs | 6 |
| 27 | Signal torch | pcs | 3 |
| 28 | Signal flag (Red, yellow) | pcs | 2 each |
| 29 | Main alternator carbon brush | pcs | 2 |
| 30 | Traction motor carbon brush | pcs | 12 |
| 31 | Starter motor carbon brush | pcs | 3 |
| 32 | Lube oil pump and fuel delivery pump | pcs | 4 |

0038

| | | | |
|----|-------------------------------|-----|---|
| | motor carbon brush | | |
| 33 | Fuse RM1 | pcs | 1 |
| 34 | Fuse RM2 | pcs | 2 |
| 35 | Headlight bulb (50W) | pcs | 2 |
| 36 | White marker lamp bulb (200W) | pcs | 2 |
| 37 | Red marker lamp bulb (LED) | pcs | 2 |
| 38 | Brake shoe | pcs | 1 |



Note: The above list of free of charge attendant tools will be finally determined after the locomotive's design is approved by the Principal.

2. WAGONS

The following list for free of charge attendant tools for wagons is just for reference.

2.1 List of Attendant Tools

| S/N | Description | Quantity | Remarks |
|-----|-------------------------------------|------------------|---------|
| 1 | Wheel diameter ruler | 2 | Special |
| 2 | Wheel tread detection model | 2 | Special |
| 3 | Adjustable wrench (200mm, 400mm) | 5 for each type | |
| 4 | Ratchet wrench (17, 19, 20, 22, 24) | 5 for each type | |
| 5 | Pipe tongs (450mm, 600mm) | 5 for each type | |
| 6 | Inspection hammer | 10 | |
| 7 | Tape measure, 5m tape measure | 5 for each type | |
| 8 | 300mm, 500mm metal ruler | 10 for each type | |
| 9 | Flashlight | 10 | |

Note: The above list will be finally determined after the wagons' design is approved by the Principal.

3. HEAVY MACHINERY

The following list of free of charge attendant tools is for one set of machine. The following lists are just for reference. The lists will be finally determined after the heavy Machinery' design is approved by the Principal.

3.1 329DL Hydraulic Excavator

| Items | Qty. | PART NBR | DESCRIPTION |
|-------|------|-----------|-------------------------|
| 1 | 1 | 65-255-22 | S/DVR TANG THRU 8MMX10" |

0088

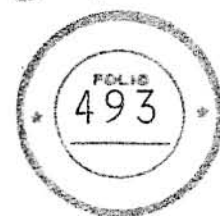

| Items | Qty. | PART NBR | DESCRIPTION |
|-------|------|----------|---------------------------------|
| 2 | 1 | 80308 | Long Hex Chrome Plated 4.0mm |
| 3 | 1 | 80310 | Long Hex Chrome Plated 5.0mm |
| 4 | 1 | 80312 | Long Hex Chrome Plated 6.0mm |
| 5 | 1 | 80314 | Long Hex Chrome Plated 8.0mm |
| 6 | 1 | 80316 | Long Hex I Chrome Plated 10.0mm |
| 7 | 1 | 80320 | Long Hex Black Plated 14.0mm |
| 8 | 1 | 47204 | WRENCH ADJUSTABLE 10" |
| 9 | 1 | 70502 | PLIER-SLIP JOINT 8" |
| 10 | 1 | 13301 | SOCKET STD 1/2"DR 6PT 10MM |
| 11 | 1 | 13302 | SOCKET STD 1/2"DR 6PT 11MM |
| 12 | 1 | 13304 | SOCKET STD 1/2"DR 6PT 13MM |
| 13 | 1 | 13307 | SOCKET STD 1/2"DR 6PT 16MM |
| 14 | 1 | 13309 | SOCKET STD 1/2"DR 6PT 18MM |
| 15 | 1 | 13313 | SOCKET STD 1/2"DR 6PT 22MM |
| 16 | 1 | 13315 | SOCKET STD 1/2"DR 6PT 24MM |
| 17 | 1 | 13317 | SOCKET STD 1/2"DR 6PT 30MM |
| 18 | 1 | 13902 | RATCHET 1/2"DR QUICK REL |
| 19 | 1 | 13909 | HANDLE FLEX 1/2"DR 250MM |
| 20 | 1 | 13904 | EXTENSION BAR 1/2"DR 5" |
| 21 | 1 | 25104 | SOCKET TORX BIT 1/2"DR T-30 |
| 22 | 1 | 25107 | SOCKET TORX BIT 1/2"DR T-50 |



0088

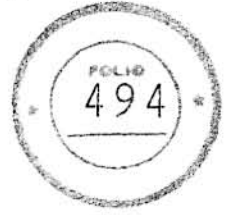

| Items | Qty. | PART NBR | DESCRIPTION |
|-------|------|------------|-------------------------------|
| 23 | 1 | 40211 | WRENCH COMB SL 16MM |
| 24 | 1 | 40213 | WRENCH COMB SL 18MM |
| 25 | 1 | 40214 | WRENCH COMB SL 19MM |
| 26 | 1 | 40216 | WRENCH COMB SL 21MM |
| 27 | 1 | 40217 | WRENCH COMB SL 22MM |
| 28 | 1 | heavy duty | GEESE GUN(HEAVY DUTY) |
| 29 | 1 | 518-0790 | METRIC FEELER GAUGE SET |
| 30 | 1 | | DRIFT PUNCH |
| 31 | 1 | TB135 | GENERAL PURPOSE BOX WITH TRAY |
| 32 | 1 | | HAMMER 32 OZ ball pain |
| 33 | 1 | | FILLTER WRENCH |

3.2 966H Wheel Loader

| Item | Qty. | Part No. | Description |
|------|------|----------|--|
| 1 | 1 | 1P-0545 | Tire Pressure Gauge |
| 2 | 1 | 1S-0259 | Socket, 1/2 in, 1/2 in drive, 12Pt. |
| 3 | 1 | 4C-9592 | Combination Wrench, 3/8 in |
| 4 | 1 | 4C-9594 | Combination Wrench, 1/2 in |
| 5 | 1 | 4C-9595 | Combination Wrench, 9/16 in |
| 6 | 1 | 4C-9596 | Combination Wrench, 5/8 in |
| 7 | 1 | 4C-9597 | Combination Wrench, 11/16 in |
| 8 | 1 | 4C-9598 | Combination Wrench, 3/4 in |
| 9 | 1 | 4C-9605 | Combination Wrench, 5/16 in |
| 10 | 1 | 5F-4764 | Pry Bar, 406.4 mm(16.00 in)long |
| 11 | 1 | 6V-7932 | Screwdriver, Standard 3/8 in tip, 323.9 mm(12.75 in)long |
| 12 | 1 | 6V-7934 | Screwdriver, PHILLIPS™ No.2, 247.7 mm(9.75 in) long |
| 13 | 1 | 8F-9866 | Grease Gun |
| 14 | 1 | 8H-8536 | Socket, 1 5/16 in, 3/4 in drive, 12Pt. |

X

0088

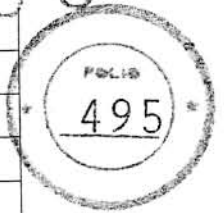

| | | | |
|----|---|----------|---|
| 15 | 1 | 8H-8537 | Socket, 1 1/2 in, 3/4 in drive, 12Pt. |
| 16 | 1 | 8H-8538 | Socket, 1 11/16 in, 3/4 in drive, 12Pt. |
| 17 | 1 | 8H-8541 | Socket, 1 7/8 in, 3/4 in drive, 12Pt. |
| 18 | 1 | 8H-8549 | Socket, 9/16 in, 1/2 in drive, 12Pt. |
| 19 | 1 | 8H-8551 | Socket, 1 1/16 in, 1/2 in drive, 12Pt. |
| 20 | 1 | 8H-8552 | Socket, 3/4 in, 1/2 in drive, 12Pt. |
| 21 | 1 | 8H-8553 | Socket, 13/16 in, 1/2 in drive, 12Pt. |
| 22 | 1 | 8H-8554 | Socket, 7/8 in, 1/2 in drive, 12Pt. |
| 23 | 1 | 8H-8555 | Socket, 15/16 in, 1/2 in drive, 12Pt. |
| 24 | 1 | 8H-8559 | Socket Extension, 1/2 in drive, 254.0 mm(10.00 in) long |
| 25 | 1 | 8H-8581 | Feeler Gauge, 25 blade, .0015 in to .025 in |
| 26 | 1 | 9S-1730 | Socket, 1 1/8 in, 1/2 in drive, 12Pt. |
| 27 | 1 | 9S-1731 | Socket, 1 1/4 in, 1/2 in drive, 12Pt. |
| 28 | 1 | 185-3630 | Filter Strap Wrench |
| 29 | 1 | 212-8144 | Petcock Socket, 1/2 in drive |
| 30 | 1 | 212-8145 | Drain Plug Socket, 1/2 in Female, 3/4 in Male |
| 31 | 1 | 213-1985 | Sliding T-Handle, 1/2 in drive, 304.8mm(12.00in)long |

3.3 M317D2 Wheel Hydraulic Excavator

| Items | Qty. | PART NBR | DESCRIPTION |
|-------|------|-----------|---------------------------------|
| 1 | 1 | 65-255-22 | S/DVR TANG THRU 8MMX10" |
| 2 | 1 | 80308 | Long Hex Chrome Plated 4.0mm |
| 3 | 1 | 80310 | Long Hex Chrome Plated 5.0mm |
| 4 | 1 | 80312 | Long Hex Chrome Plated 6.0mm |
| 5 | 1 | 80314 | Long Hex Chrome Plated 8.0mm |
| 6 | 1 | 80316 | Long Hex I Chrome Plated 10.0mm |
| 7 | 1 | 80320 | Long Hex Black Plated 14.0mm |
| 8 | 1 | 47204 | WRENCH ADJUSTABLE 10" |
| 9 | 1 | 70502 | PLIER-SLIP JOINT 8" |
| 10 | 1 | 13301 | SOCKET STD 1/2"DR 6PT 10MM |

